



ShanghaiTech University
上海科技大学

School of Information Science and Technology
信息科学与技术学院

Mobile Robotics

Sören Schwertfeger / 师泽仁

Lecture 5

Outline

- ROS transforms
- High-level Control Schemes
- Sensors

ROS: Transforms : TF

- <http://wiki.ros.org/tf>
- <http://wiki.ros.org/tf/Tutorials>

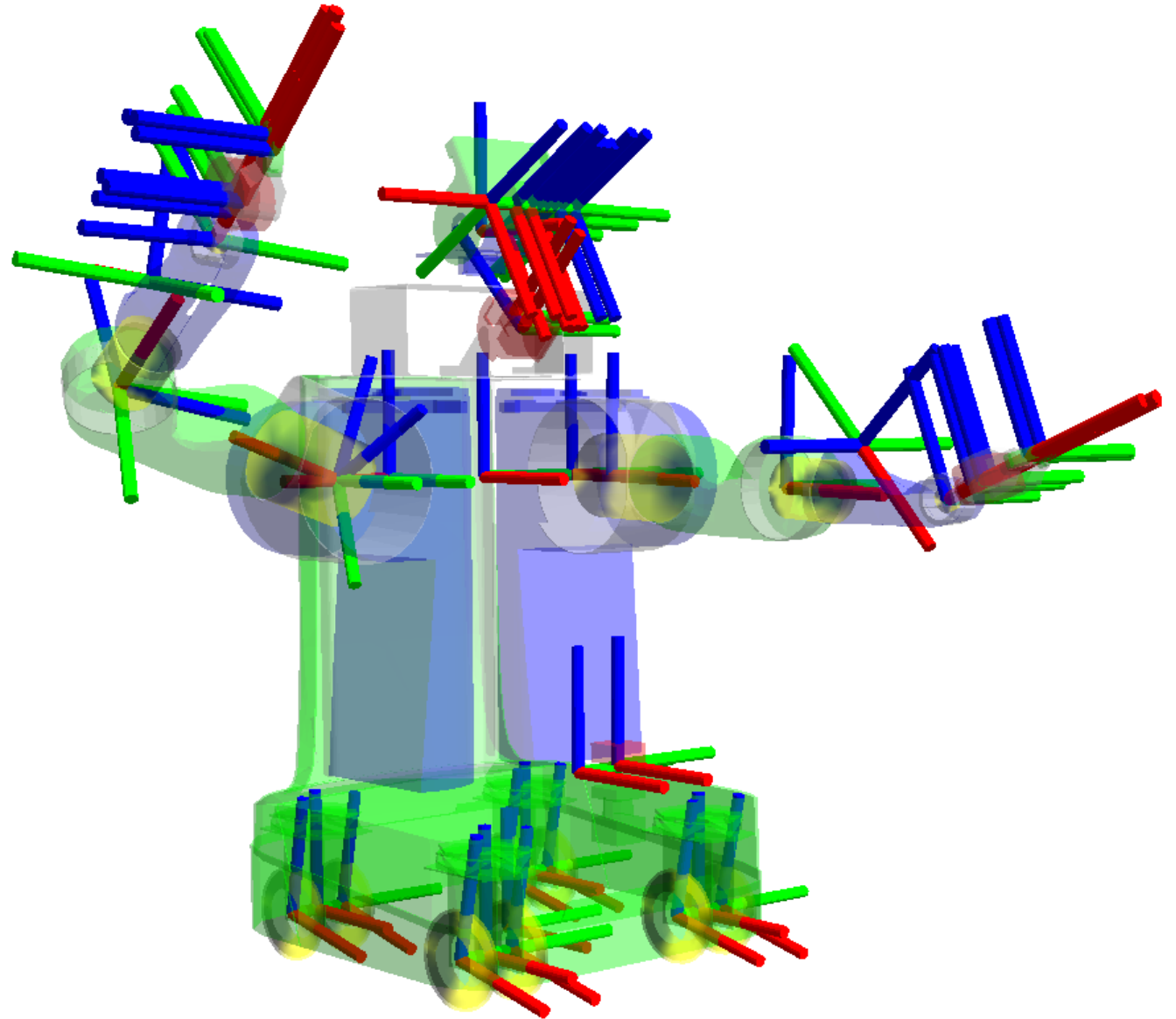

ROS geometry_msgs/TransformStamped

- $\text{header.frame_id} \downarrow \text{id}[\text{header.stamp}] \mathbf{T}$
 $\text{child} \downarrow \text{frame} \downarrow \text{id}[\text{header.stamp}]$
- Transform between header (time and reference frame) and child_frame
- 3D Transform representation:
 - geometry_msgs/Transform:
 - Vector3 for translation (position)
 - Quaternion for rotation (orientation)

```
rosmmsg show geometry_msgs/TransformStamped

std_msgs/Header header
  uint32 seq
  time stamp
  string frame_id
  string child_frame_id
geometry_msgs/Transform transform
  geometry_msgs/Vector3 translation
    float64 x
    float64 y
    float64 z
  geometry_msgs/Quaternion rotation
    float64 x
    float64 y
    float64 z
    float64 w
```

ROS tf2_msgs/TFMessage

- An array of TransformStamped
- Transforms form a tree
- Transform listener: traverse the tree
 - tf::TransformListener listener;
- Get transform:
 - tf::StampedTransform transform;
 - listener.lookupTransform("/base_link", "/camera1", ros::Time(0), transform);
 - ros::Time(0): get the latest transform
 - Will calculate transform by chaining intermediate transforms, if needed

```
rosmmsg show tf2_msgs/TFMessage
geometry_msgs/TransformStamped[] transforms
  std_msgs/Header header
    uint32 seq
    time stamp
    string frame_id
  string child_frame_id
  geometry_msgs/Transform transform
    geometry_msgs/Vector3 translation
      float64 x
      float64 y
      float64 z
    geometry_msgs/Quaternion rotation
      float64 x
      float64 y
      float64 z
      float64 w
```

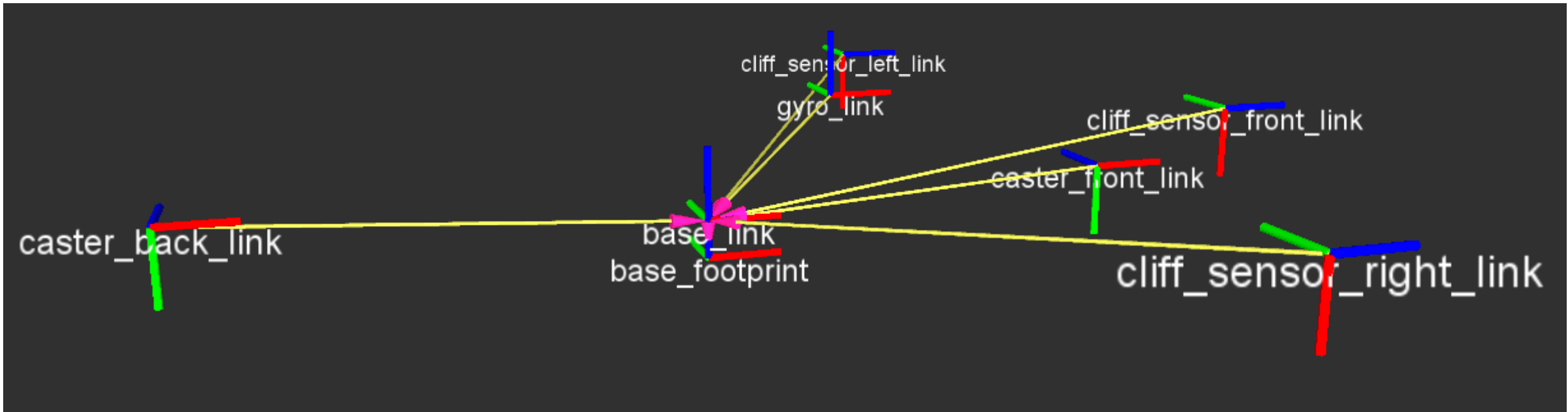
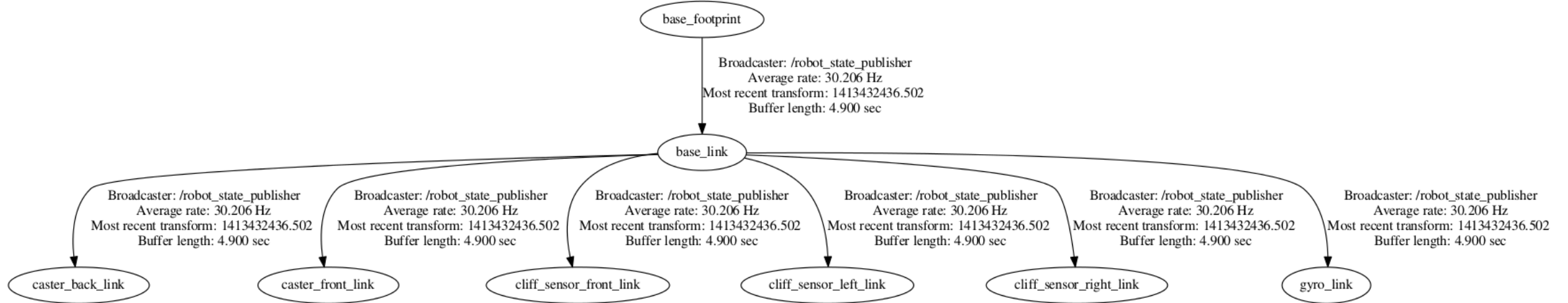

Transforms in ROS

- Imagine: Object recognition too 3 seconds – it found an object with:
 - `tf::Transform object_transform_camera;` // ${}_{Obj}^{Cam[X]} \mathbf{T}$ (has `tf::Vector3` and `tf::Quaternion`)
 - and header with: `ros::Time stamp;` // Timestamp of the camera image (== X)
 - and `std::string frame_id;` // Name of the frame (“Cam”)
- Where is the object in the global frame (= odom frame) “odom” ${}_{Obj}^G \mathbf{T}$?
 - `tf::StampedTransform object_transform_global;` // the resulting frame
 - `listener.lookupTransform(header.frame_id, “/odom”, header.stamp, object_transform_global);`
- `tf::TransformListener` keeps a history of transforms – by default 10 seconds

HIGH-LEVEL CONTROL SCHEMES

General Control Scheme for Mobile Robot Systems

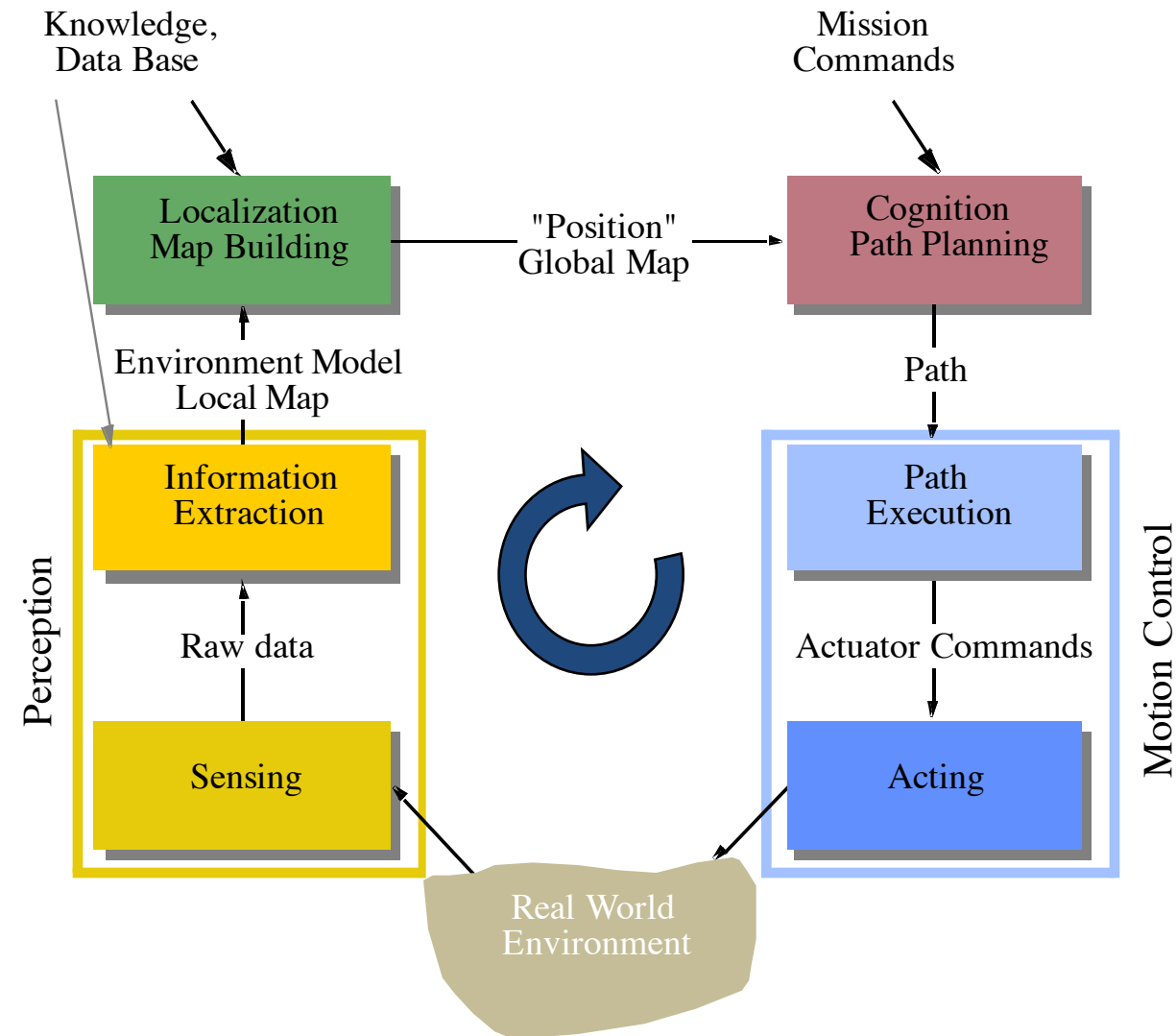

Control Architectures / Strategies

- Control Loop
 - **dynamically changing**
 - **no compact model available**
 - **many sources of uncertainty**

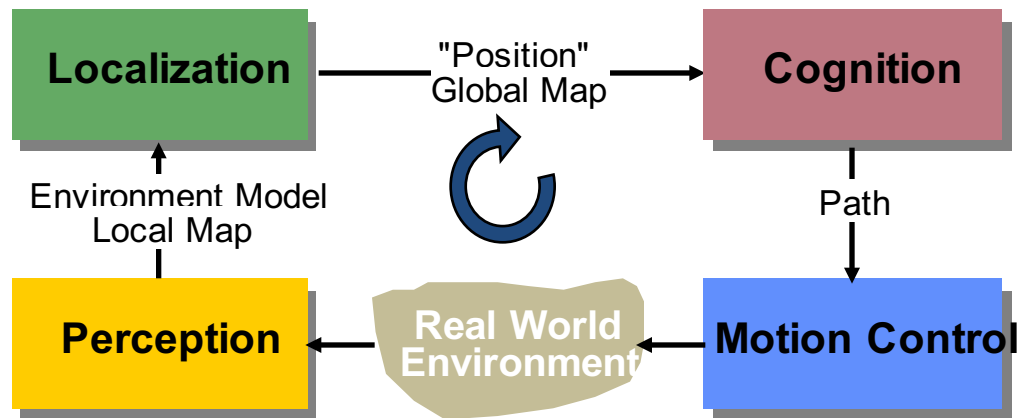

Two Approaches

Classical AI

- complete modeling
- function based
- horizontal decomposition

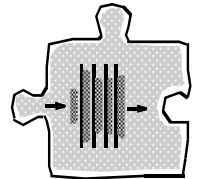

New AI (Nouvelle AI)

- sparse or no modeling
- behavior based
- vertical decomposition
- bottom up

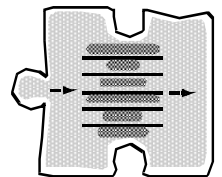

Two Approaches

- **Classical AI**
(model based navigation)
 - complete modeling
 - function based
 - horizontal decomposition
- **New AI**
(behavior based navigation)
 - sparse or no modeling
 - behavior based
 - vertical decomposition
 - bottom up
- **Possible Solution**
 - Combine Approaches

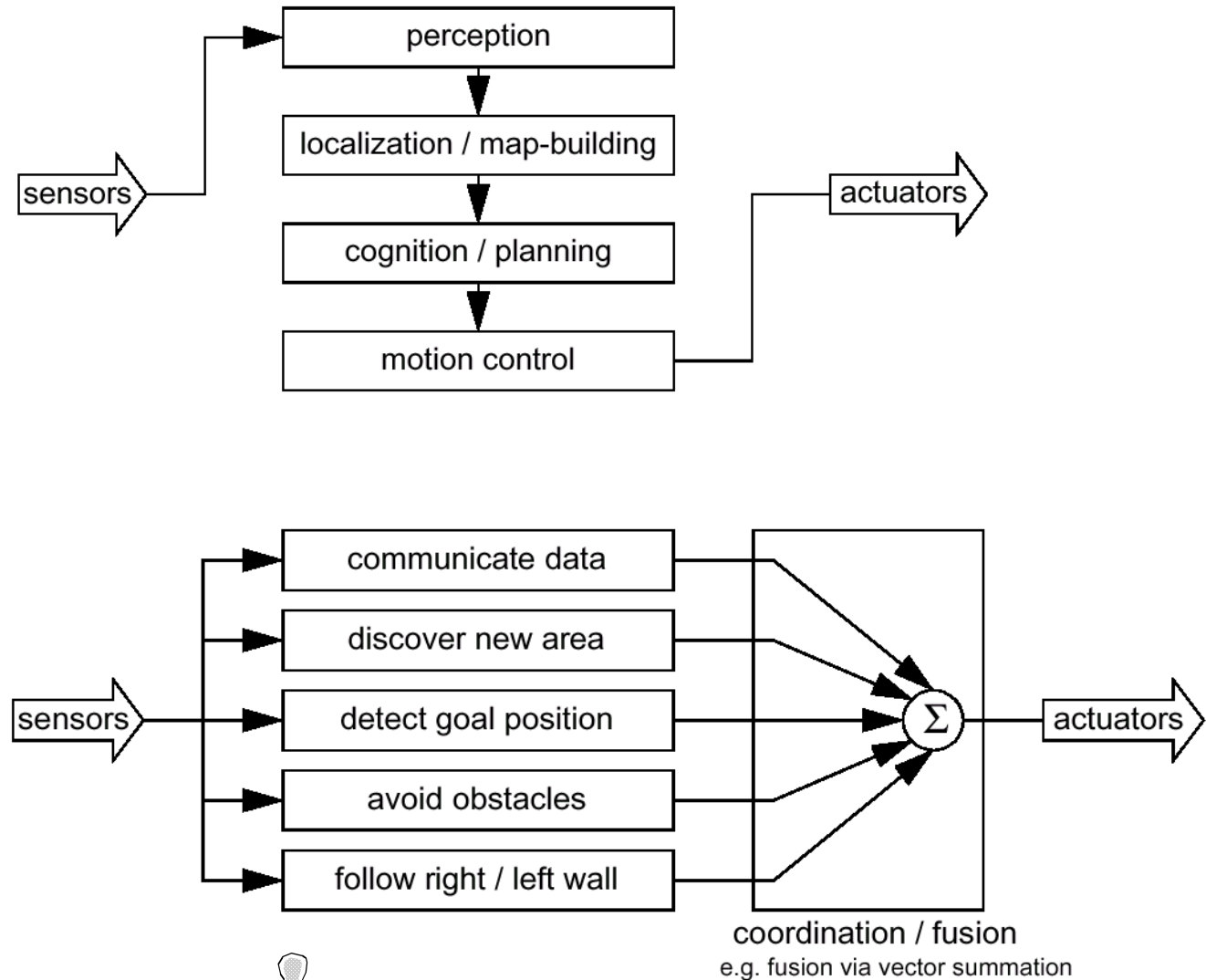

Mixed Approach Depicted into the General Control Scheme

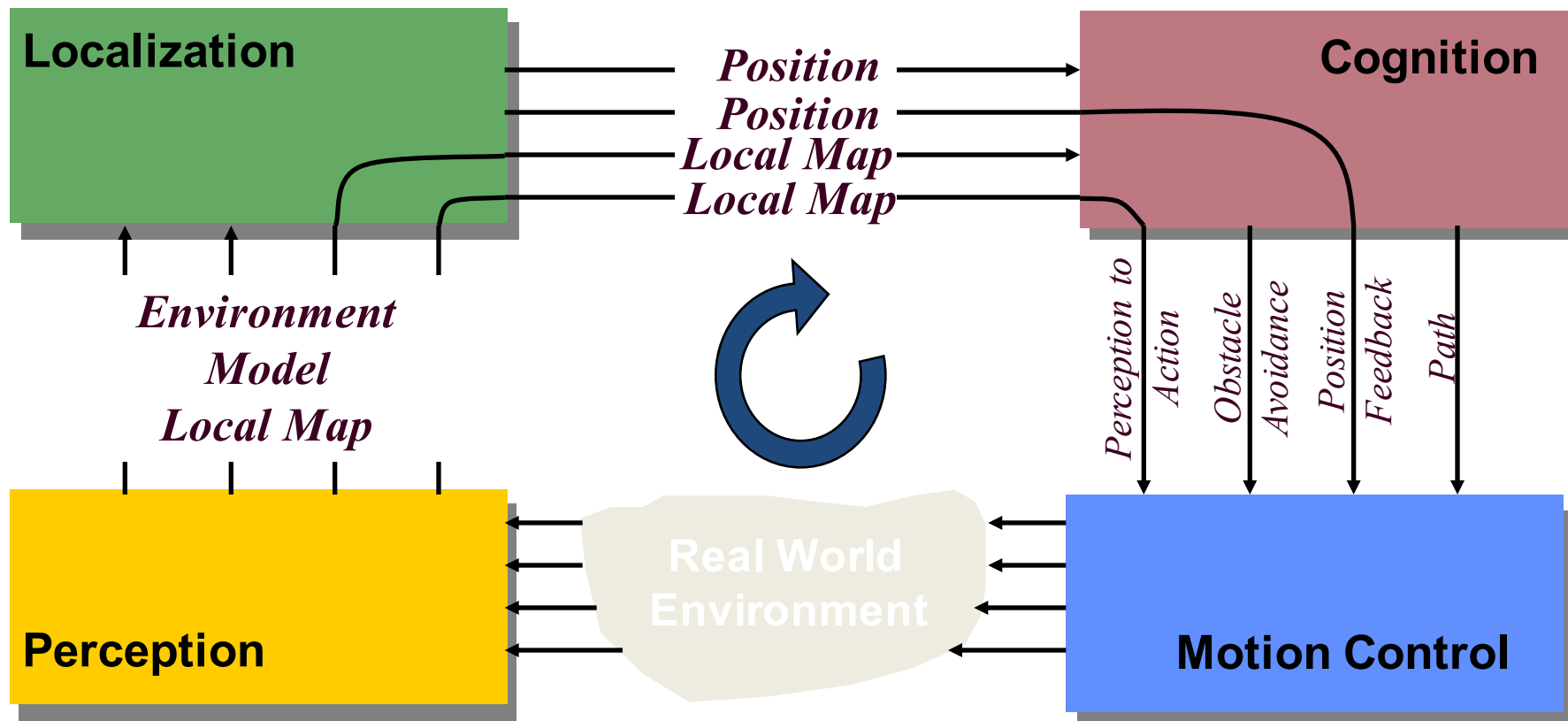
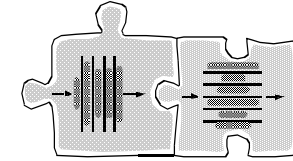

SENSORS

Introduction to Autonomous Mobile Robots page 102 ff

Sensors for Mobile Robots

- Why should a robotics engineer know about sensors?
 - Is the **key technology** for perceiving the environment
 - **Understanding the physical principle** enables appropriate use
- Understanding the physical principle behind sensors enables us:
 - To **properly select** the sensors for a given application
 - To **properly model** the sensor system, e.g. resolution, bandwidth, **uncertainties**

Example

- Jacobs Robotics Rugbot
- Search and Rescue Robot
- RoboCup Rescue

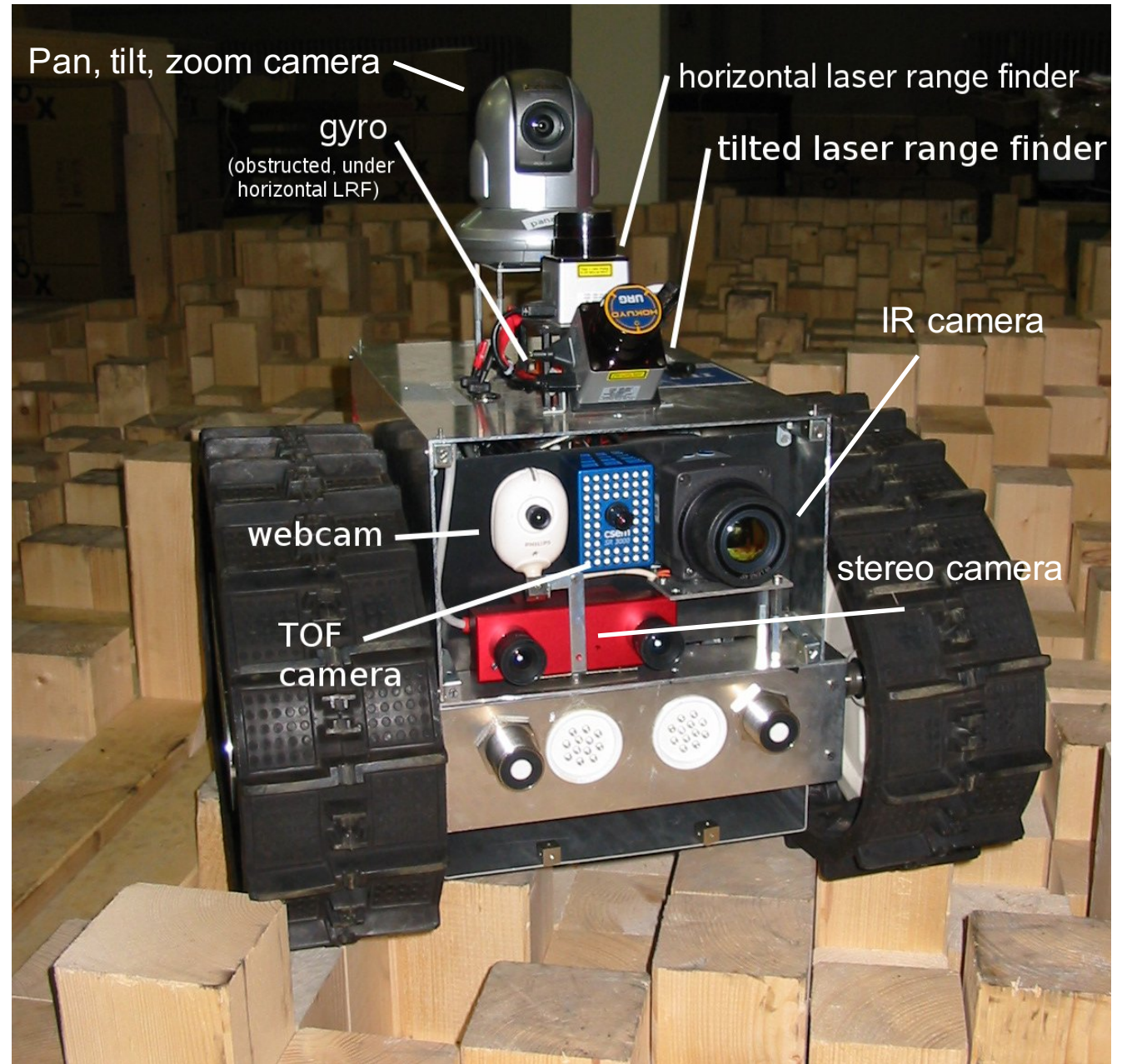

Dealing with Real World Situations

- Reasoning about a situation



- Cognitive systems have to interpret situations based on uncertain and only partially available information
- The need ways to learn functional and contextual information (semantics / understanding)

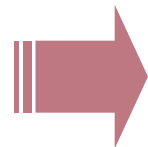

Probabilistic Reasoning

Perception for Mobile Robots

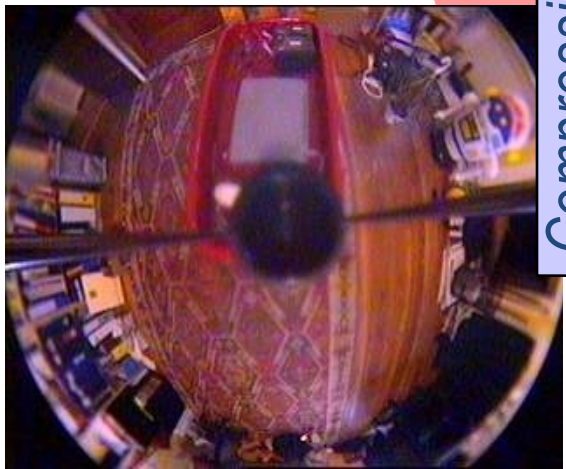

Compressing Information

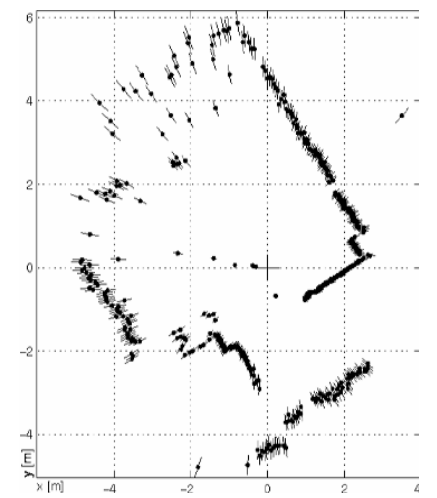
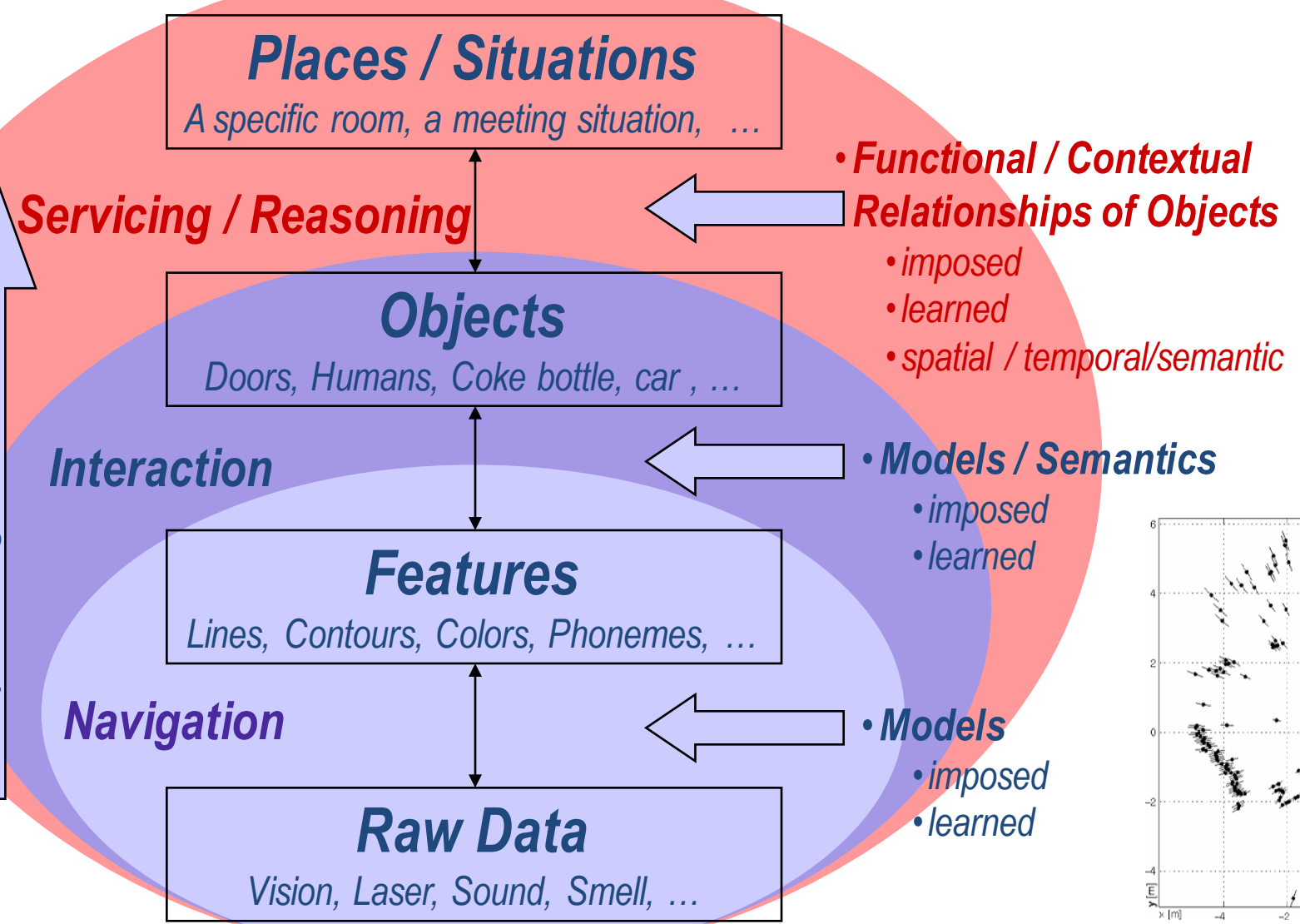

The Challenge

- Perception and models are strongly linked

*What is the difference
in brightness?*

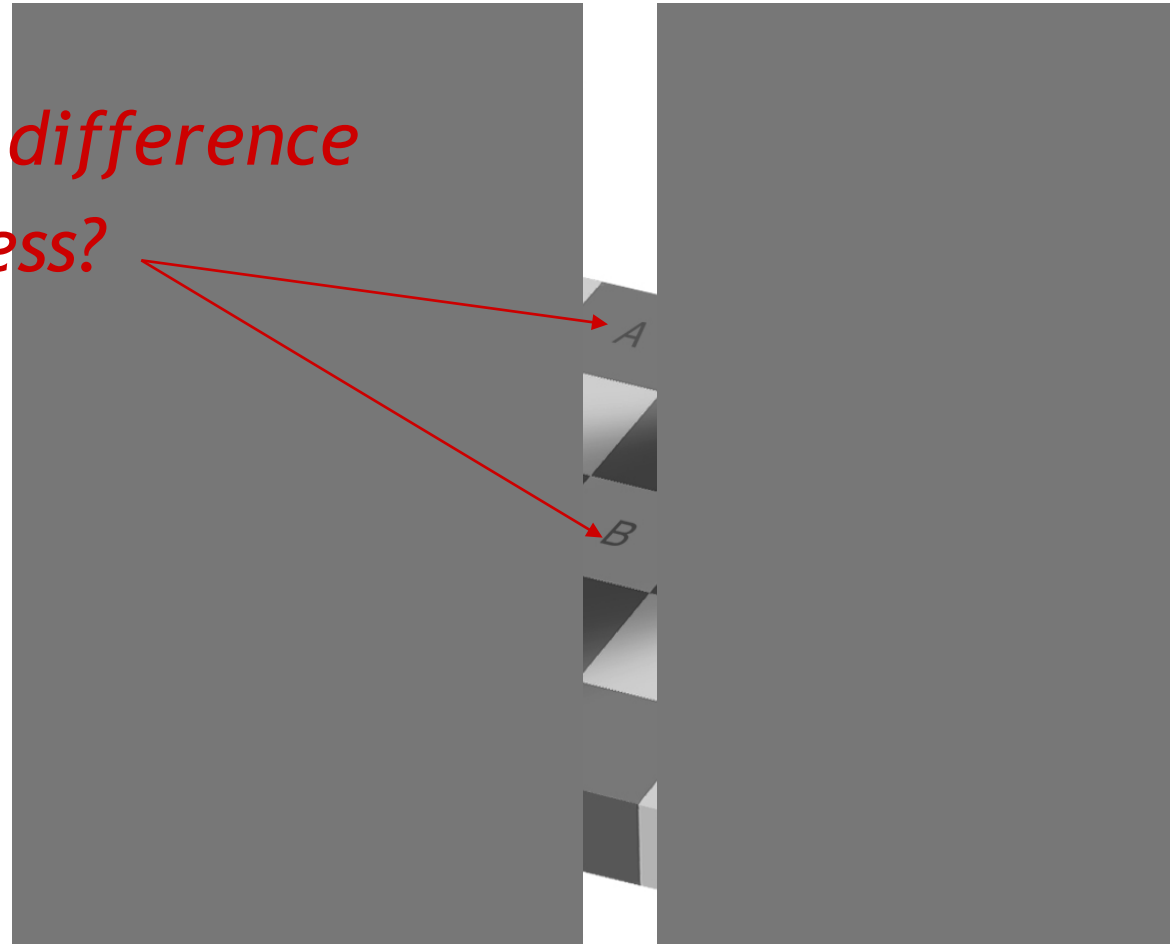

- http://web.mit.edu/persci/people/adelson/checkershadow_downloads.html

Classification of Sensors

- What:
 - Proprioceptive sensors
 - measure values internally to the system (robot),
 - e.g. motor speed, wheel load, heading of the robot, battery status
 - Exteroceptive sensors
 - information from the robots environment
 - distances to objects, intensity of the ambient light, unique features.
- How:
 - Passive sensors
 - Measure energy coming from the environment
 - Active sensors
 - emit their proper energy and measure the reaction
 - better performance, but some influence on environment

General Classification (1)

General classification (typical use)	Sensor Sensor System	PC or EC	A or P
Tactile sensors (detection of physical contact or closeness; security switches)	Contact switches, bumpers	EC	P
	Optical barriers	EC	A
	Noncontact proximity sensors	EC	A
Wheel/motor sensors (wheel/motor speed and position)	Brush encoders	PC	P
	Potentiometers	PC	P
	Synchros, resolvers	PC	A
	Optical encoders	PC	A
	Magnetic encoders	PC	A
	Inductive encoders	PC	A
	Capacitive encoders	PC	A
Heading sensors (orientation of the robot in relation to a fixed reference frame)	Compass	EC	P
	Gyroscopes	PC	P
	Inclinometers	EC	A/P

A, active; P, passive; P/A, passive/active; PC, proprioceptive; EC, exteroceptive.

General Classification (2)

General classification (typical use)	Sensor Sensor System	PC or EC	A or P
Ground-based beacons (localization in a fixed reference frame)	GPS	EC	A
	Active optical or RF beacons	EC	A
	Active ultrasonic beacons	EC	A
	Reflective beacons	EC	A
Active ranging (reflectivity, time-of-flight, and geo- metric triangulation)	Reflectivity sensors	EC	A
	Ultrasonic sensor	EC	A
	Laser rangefinder	EC	A
	Optical triangulation (1D)	EC	A
	Structured light (2D)	EC	A
Motion/speed sensors (speed relative to fixed or moving objects)	Doppler radar	EC	A
	Doppler sound	EC	A
Vision-based sensors (visual ranging, whole-image analy- sis, segmentation, object recognition)	CCD/CMOS camera(s) Visual ranging packages Object tracking packages	EC	P

Characterizing Sensor Performance (1)

Measurement in real world environment is error prone

- Basic sensor response ratings
 - Dynamic range
 - ratio between upper and lower limits, usually in decibels (dB, power)
 - e.g. power measurement from 1 mW to 20 W

$$10 \cdot \log \left[\frac{20}{0.001} \right] = 43 \text{ dB}$$

$$P = U \cdot I = \frac{1}{R} U^2$$

- e.g. voltage measurement $20 \cdot \log \left[\frac{20}{0.001} \right] = 86 \text{ dB}$ 10 V

- *20 instead of 10 because square of voltage is equal to power!!*

Characterizing Sensor Performance (2)

- Basic sensor response ratings (cont.)
 - Range
 - upper limit
 - Resolution
 - minimum difference between two values
 - usually: lower limit of dynamic range = resolution
 - for digital sensors it is usually the A/D resolution.
 - e.g. 5V / 255 (8 bit)

- Linearity

- variation of output signal as function of the input signal
- linearity is less important when signal is treated with a computer

$$x \rightarrow f(x)$$

$$y \rightarrow f(y)$$

$$\alpha \cdot x + \beta \cdot y \rightarrow f(\alpha \cdot x + \beta \cdot y) = \alpha \cdot f(x) + \beta \cdot f(y)$$

Characterizing Sensor Performance (3)

- Basic sensor response ratings (cont.)
 - Bandwidth or Frequency
 - the speed with which a sensor can provide a stream of readings
 - usually there is an upper limit depending on the sensor and the sampling rate
 - lower limit is also possible, e.g. acceleration sensor
 - one has also to consider phase (delay) of the signal

In Situ Sensor Performance (1)

Characteristics that are especially relevant for real world environments

- Sensitivity $\frac{dy}{dx}$
 - ratio of output change to input change
 - however, in real world environment, the sensor has very often high sensitivity to other environmental changes, e.g. illumination
- Cross-sensitivity (and cross-talk)
 - sensitivity to other environmental parameters (e.g. temperature, magnetic field)
 - influence of other active sensors
- Error / Accuracy
 - difference between the sensor's output and the true value

$$\left(accuracy = 1 - \frac{|m - v|}{v} \right) \quad \begin{array}{l} \text{error} \\ m = \text{measured value} \\ v = \text{true value} \end{array}$$

In Situ Sensor Performance (2)

- Error / Accuracy
 - How close to true value
- Precision
 - Reproducibility
- Systematic error -> deterministic errors
 - caused by factors that can (in theory) be modeled -> prediction
 - e.g. calibration of a laser sensor or of the distortion cause by the optic of a camera
- Random error -> non-deterministic
 - no prediction possible
 - however, they can be described probabilistically
 - e.g. Hue instability of camera, black level noise of camera ..

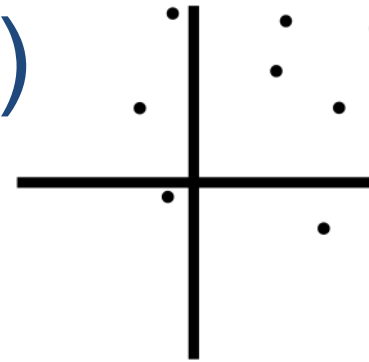

(a) Low precision and low accuracy

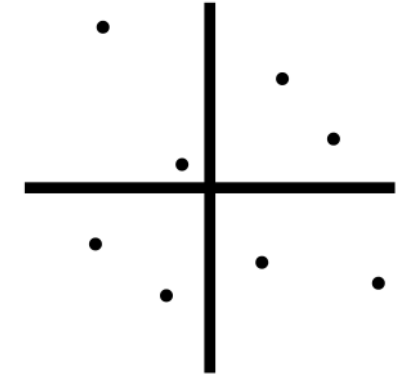

(b) Low precision and high accuracy

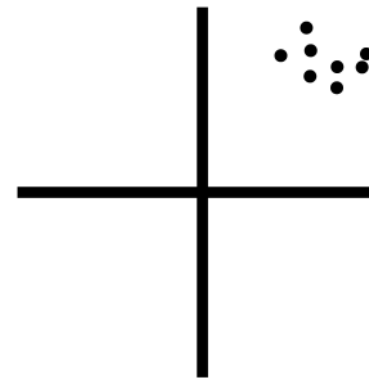

(c) High precision and low accuracy

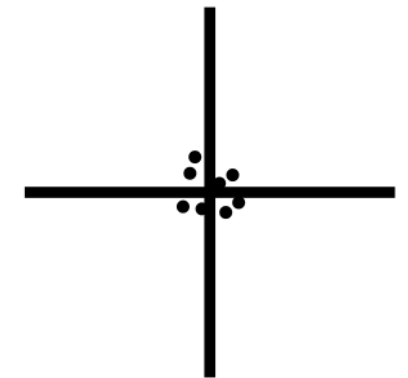

(d) High precision and high accuracy

Multi-Modal Error Distributions: The Challenges in ...

- Sensors modeled by probability distribution (random errors)
 - usually very little knowledge about the **causes** of random errors
 - often assumed to be symmetric or even **Gaussian**
 - however, it is important to realize how wrong this can be!
- Examples:
 - Sonar (ultrasonic) sensor might overestimate the distance in real environment and is therefore not symmetric
 - Thus the sonar sensor might be best modeled by two modes:
 - mode for the case that the signal returns directly
 - mode for the case that the signals returns after multi-path reflections.
 - Stereo vision system might correlate to images incorrectly, thus causing results that make no sense at all

Sensors: outline

- Optical encoders
- Heading sensors
 - Compass
 - Gyroscopes
- Accelerometer
- IMU
- GPS
- Range sensors
 - Sonar
 - Laser
 - Structured light
- Vision

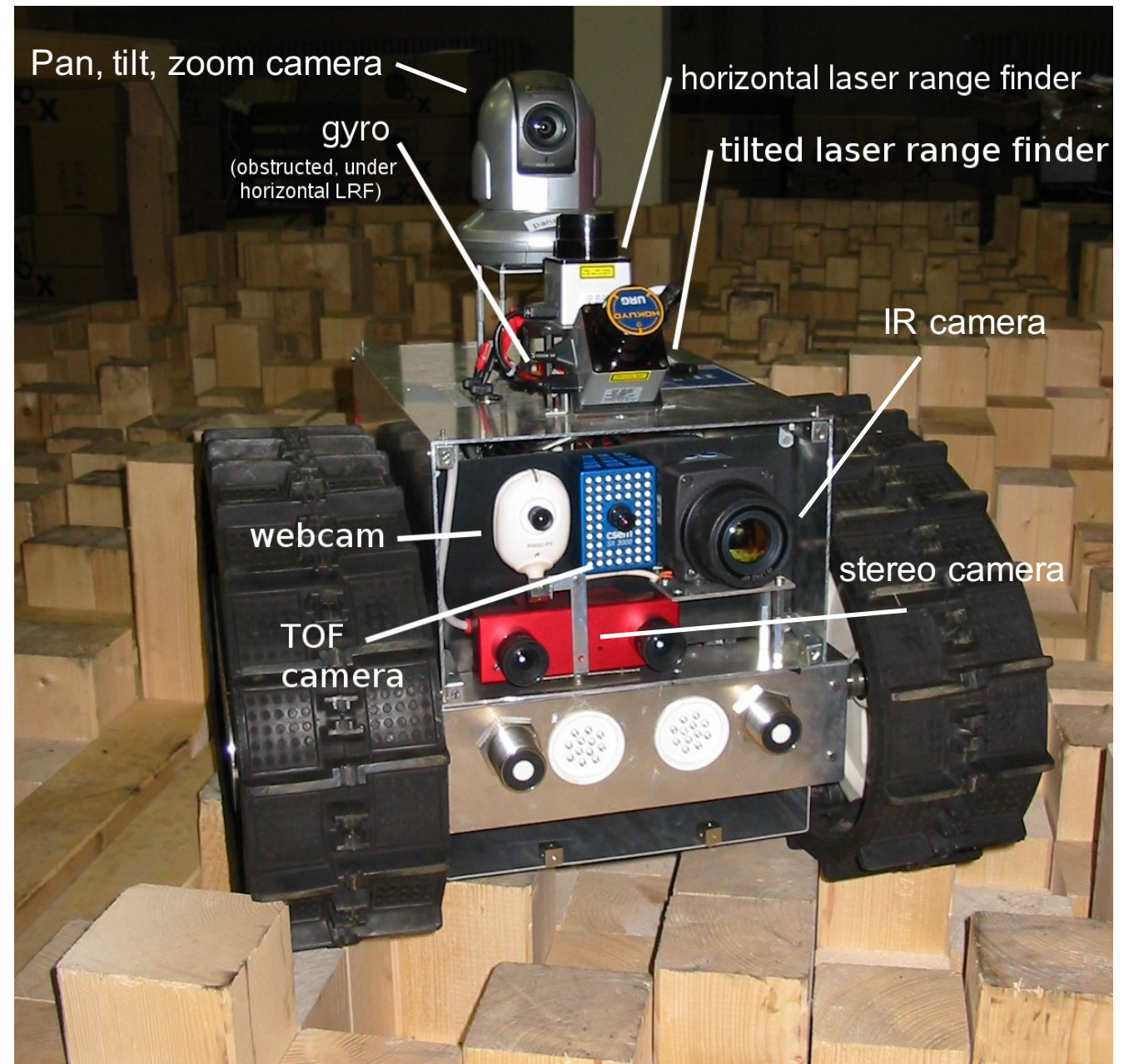

Encoders

An encoder is an electro-mechanical device that converts the angular position of a shaft to an analog or digital signal, making it an angle transducer

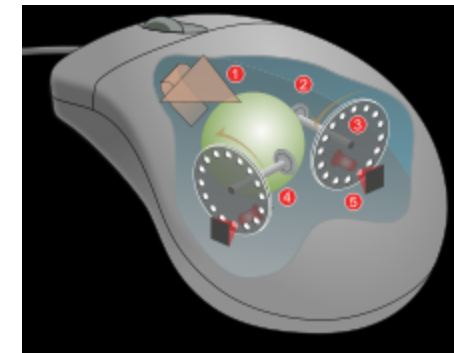
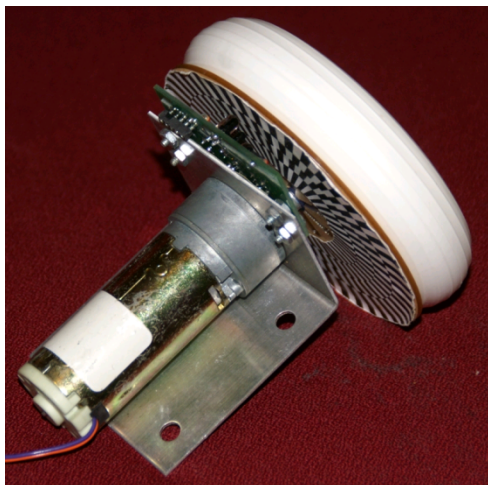

Wheel / Motor Encoders

- measure position or speed of the wheels or steering
- integrate wheel movements to get an estimate of the position -> odometry
- optical encoders are proprioceptive sensors
- typical resolutions: 64 - 2048 increments per revolution.
 - for high resolution: interpolation
- optical encoders
 - regular: counts the number of transitions but cannot tell the direction of motion
 - quadrature: uses two sensors in quadrature-phase shift. The ordering of which wave produces a rising edge first tells the direction of motion. Additionally, resolution is 4 times bigger
 - a single slot in the outer track generates a reference pulse per revolution

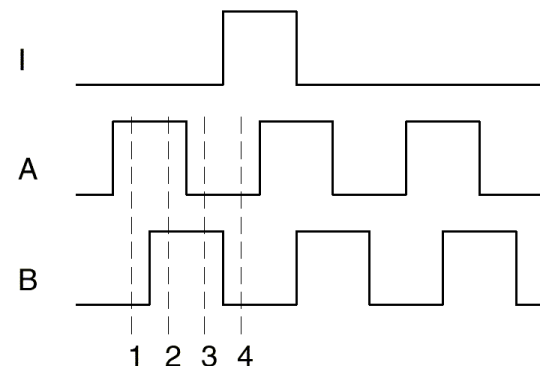
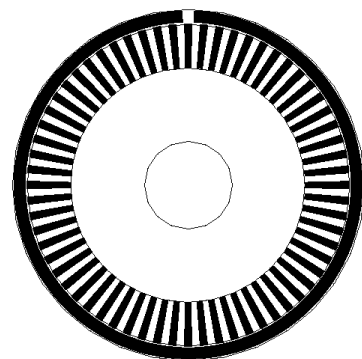

State	Ch A	Ch B
S ₁	High	Low
S ₂	High	High
S ₃	Low	High
S ₄	Low	Low

A custom made optical encoder

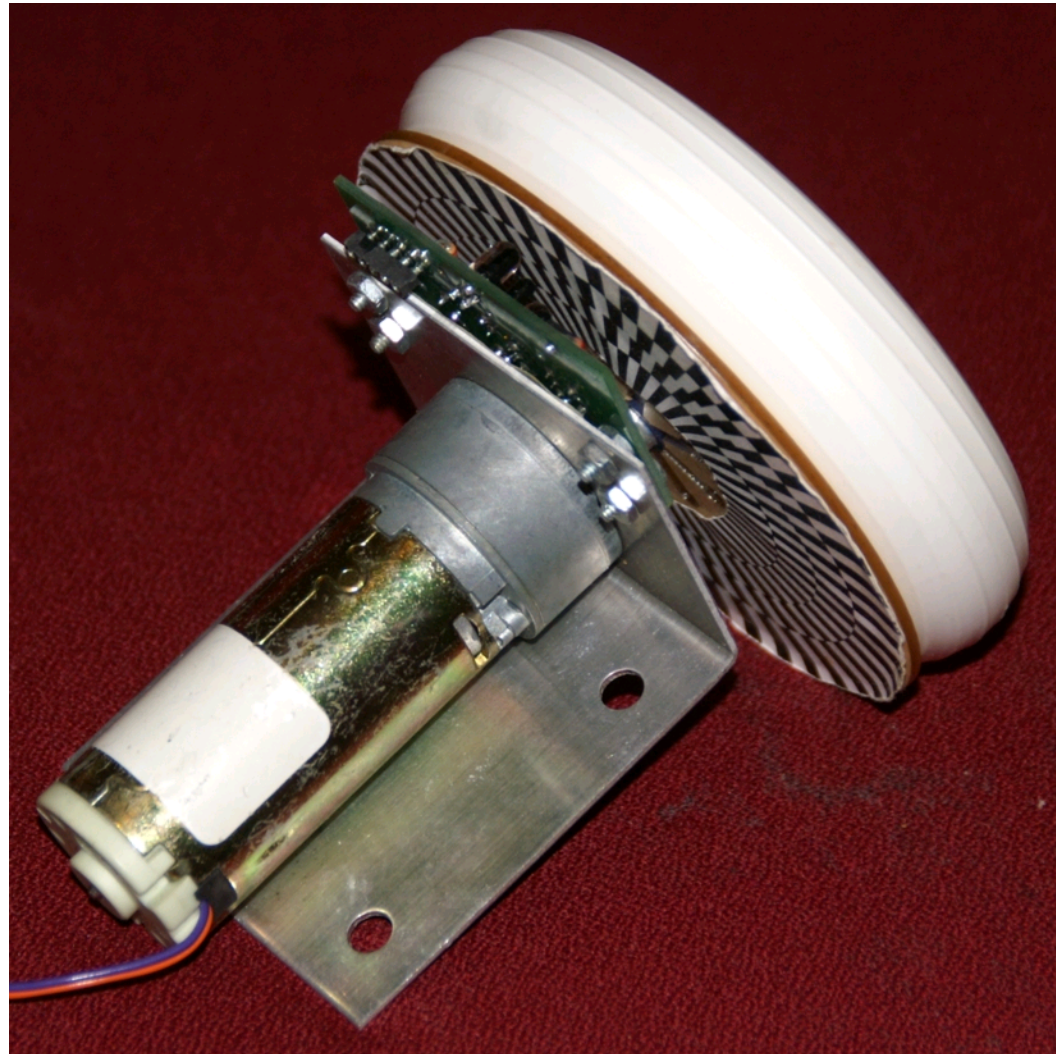

Gray Encoder

http://en.wikipedia.org/wiki/Gray_code

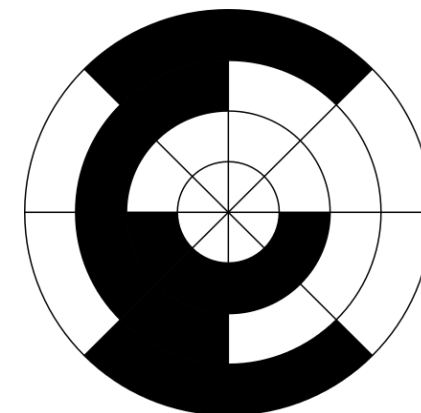

- Aka: reflected binary code, Gray Code
 - Binary numeral system where two successive values differ in only one bit
 - Also used for error correction in digital communications

- Absolute position encoder

- Normal binary => change from 011 to 100
- 2 bits change – NEVER simultaneously =>
- 011 -> 111 -> 101 -> 100 or
- 011 -> 010 -> 110 -> 100
- => wrong encoder positions might be read
- Gray encoding: only one bit change!

Dec	Gray	Binary
0	000	000
1	001	001
2	011	010
3	010	011
4	110	100
5	111	101
6	101	110
7	100	111



Heading Sensors

- Heading sensors can be proprioceptive (gyroscope, **acceleration**) or exteroceptive (compass, **inclinometer**).
- Used to determine the robots orientation and inclination.
- Allow, together with an appropriate velocity information, to integrate the movement to a position estimate.
 - This procedure is called **deduced reckoning** (ship navigation)

Compass

- Since over 2000 B.C.
 - China: suspended a piece of naturally magnetite from a silk thread to guide a chariot over land.
- Magnetic field on earth
 - absolute measure for orientation (even birds use it for migrations (2001 discovery))
- Large variety of solutions to measure the earth magnetic field
 - mechanical magnetic compass
 - direct measure of the magnetic field (Hall-effect, magneto-resistive sensors)
- Major drawback
 - weakness of the earth field ($30 \mu\text{Tesla}$)
 - easily disturbed by magnetic objects or other sources
 - bandwidth limitations (0.5 Hz) and susceptible to vibrations
 - not feasible for indoor environments for absolute orientation
 - useful indoor (only locally)

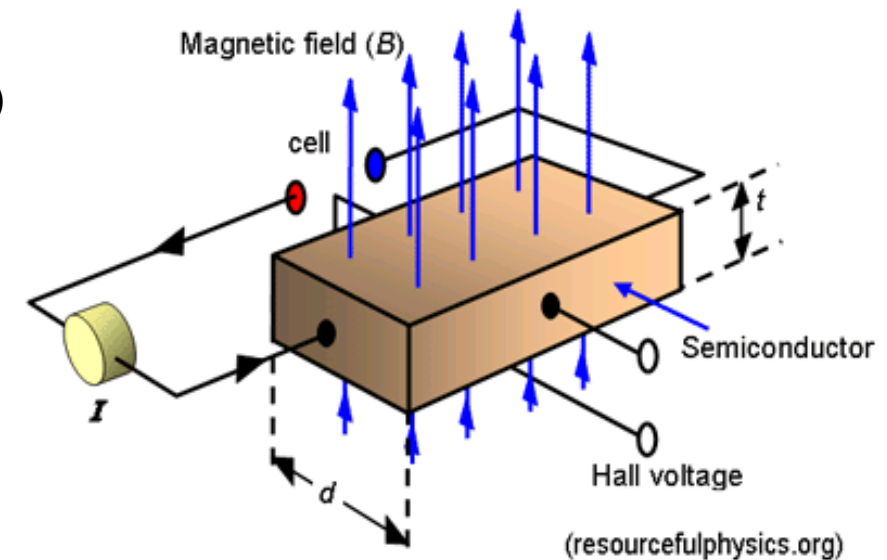

Gyroscope

- Heading sensors that preserve their orientation in relation to a fixed reference frame
 - absolute measure for the heading of a mobile system.
- Two categories, the mechanical and the optical gyroscopes
 - Mechanical Gyroscopes
 - Standard gyro (angle)
 - Rate gyro (speed)
 - Optical Gyroscopes
 - Rate gyro (speed)

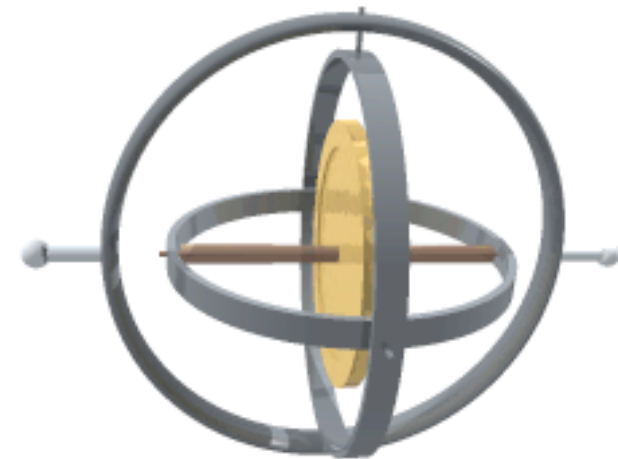

Mechanical Gyroscopes

- Concept: inertial properties of a fast spinning rotor
- Angular momentum associated with a spinning wheel keeps the axis of the gyroscope inertially stable.
- No torque can be transmitted from the outer pivot to the wheel axis
 - spinning axis will therefore be space-stable
 - however friction in the axes bearings will introduce torque and so drift
- Quality: 0.1° in 6 hours (a high quality mech. gyro costs up to 100,000 \$)
- If the spinning axis is aligned with the north-south meridian, the earth's rotation has no effect on the gyro's horizontal axis
- If it points east-west, the horizontal axis reads the earth rotation

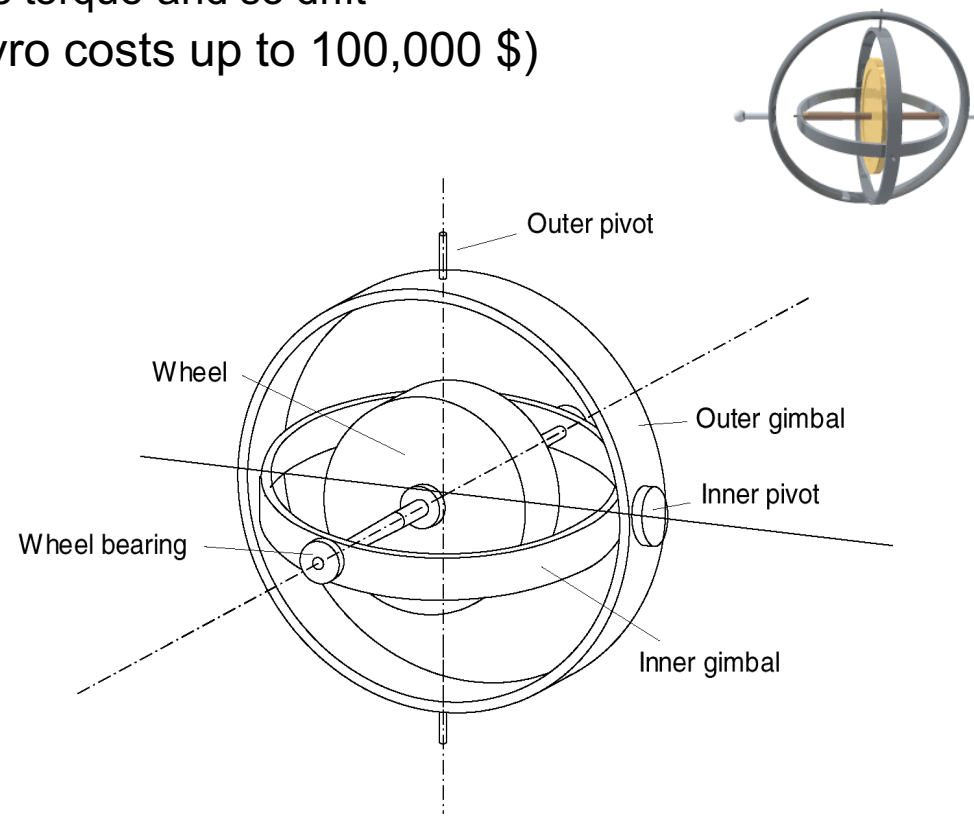

Rate gyros

- Same basic arrangement shown as regular mechanical gyros
- But: gimbals are restrained by torsional springs
 - enables to measure angular speeds instead of the orientation.

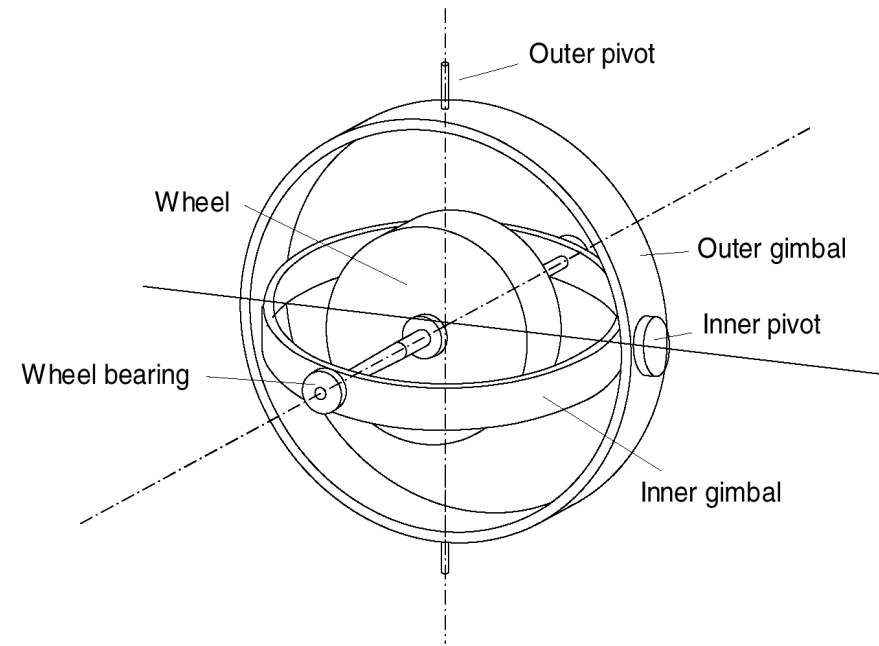

Optical Gyroscopes

- First commercial use: early 1980 in airplanes
- Optical gyroscopes
 - angular speed (heading) sensors using two monochromatic light (or laser) beams from the same source.
- One is traveling in a fiber clockwise, the other counterclockwise around a cylinder
- Laser beam traveling in direction opposite to the rotation
 - slightly shorter path
 - phase shift of the two beams is proportional to the angular velocity Ω of the cylinder
 - In order to measure the phase shift, coil consists of as much as 5Km optical fiber
- New solid-state optical gyroscopes based on the same principle are build using micro-fabrication technology.



Single axis optical gyro



3-axis optical gyro

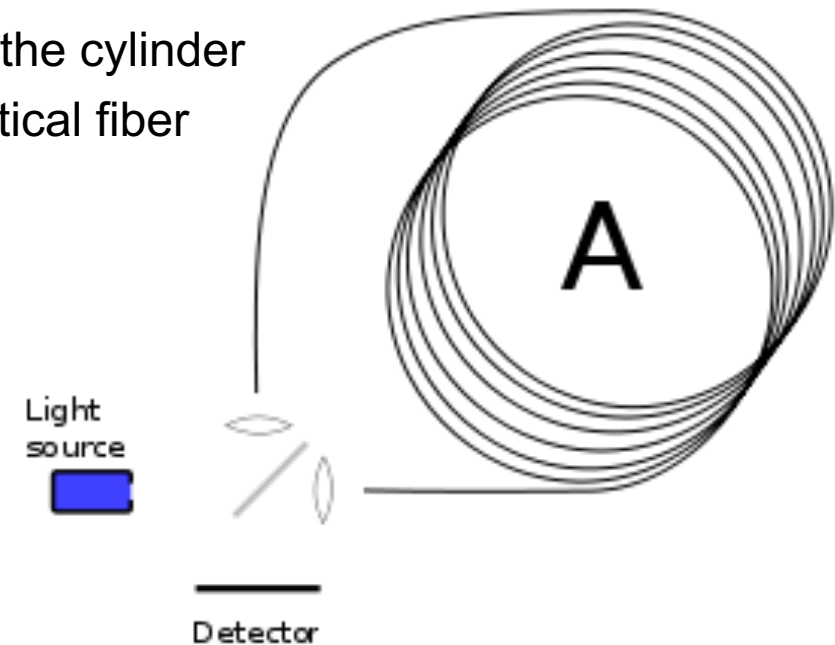

Mechanical Accelerometer

- Accelerometers measure all external forces acting upon them, including gravity
- Accelerometer acts like a spring–mass–damper system
- On the Earth's surface, the accelerometer always indicates 1g along the vertical axis
- To obtain the inertial acceleration (due to motion alone), the gravity must be subtracted.
- Bandwidth up to 50 KHz
- An accelerometer measures acceleration only along a single axis
- => mount 3 accelerometers orthogonally => three-axis accelerometer

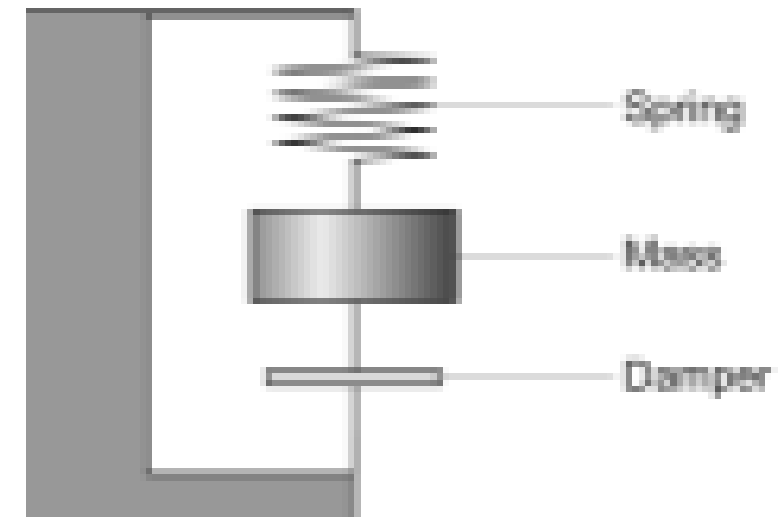

Factsheet: MEMS Accelerometer (1)

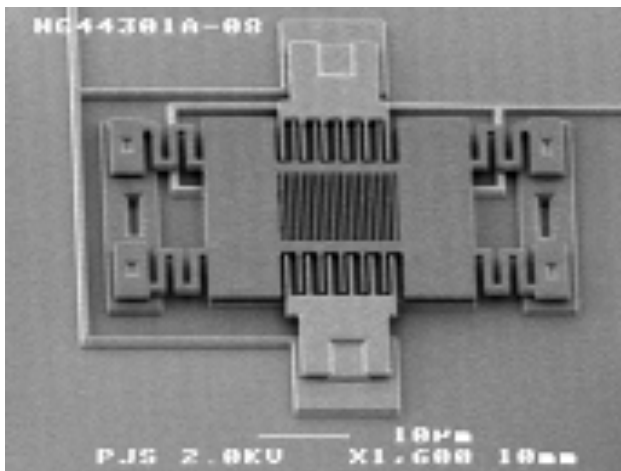
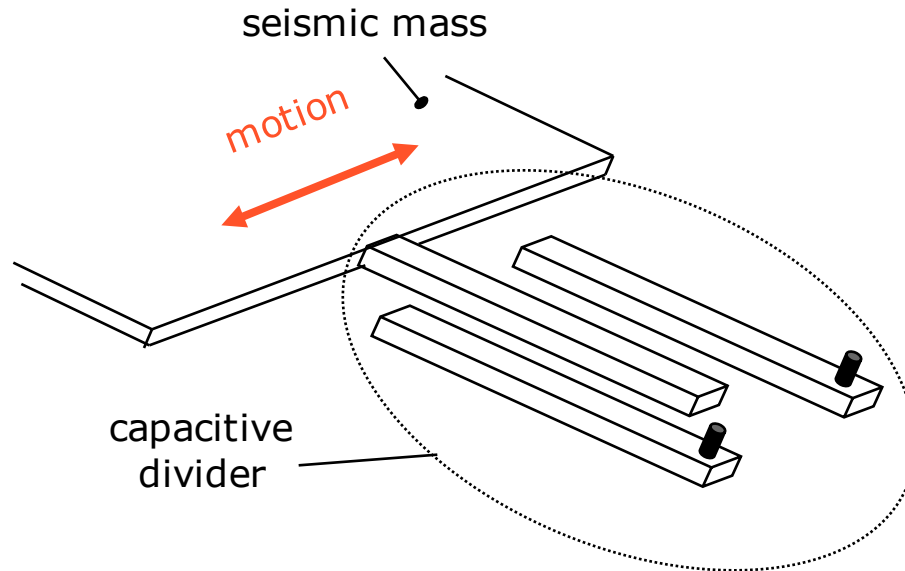

<<http://www.mems.sandia.gov/>>

1. Operational Principle

The primary transducer is a vibrating mass that relates acceleration to displacement. The secondary transducer (a capacitive divider) converts the displacement of the seismic mass into an electric signal.

2. Main Characteristics

- Can be multi-directional
- Various sensing ranges from 1 to 50 g

3. Applications

- Dynamic acceleration
- Static acceleration (inclinometer)
- Airbag sensors (± 35 g)
- Control of video games (Wii)

Inertial Measurement Unit (IMU)

- Device combining different measurement systems:
 - Gyroscopes, Accelerometers, Compass
- Estimate relative position (x, y, z), orientation (roll, pitch, yaw), velocity, and acceleration
- Gravity vector is subtracted to estimate motion
 - Initial velocity has to be known



Xsens MTI

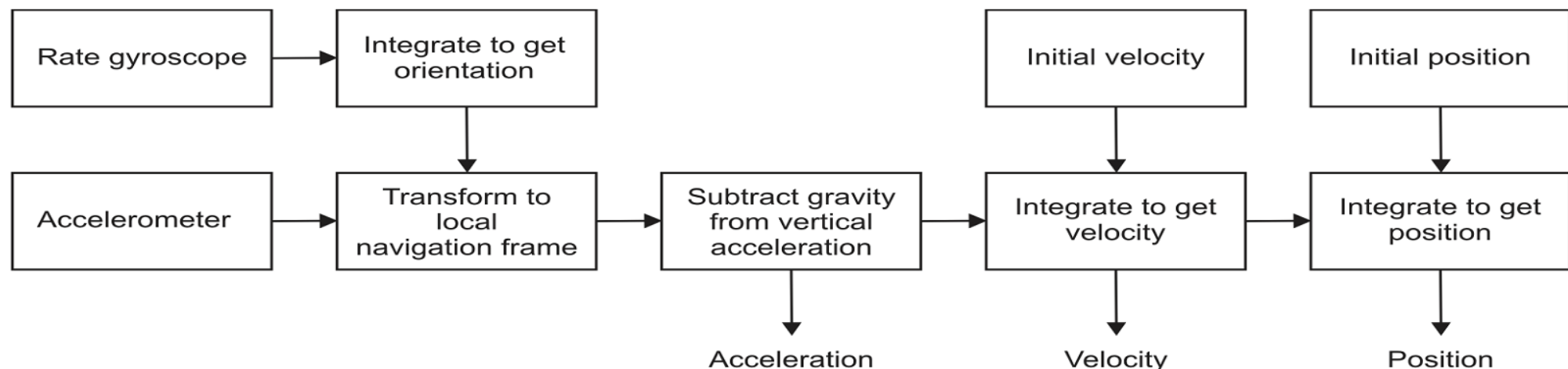

IMU Error and Drift

- Extremely sensitive to measurement errors in gyroscopes and accelerometers:
 - drift in the gyroscope unavoidably =>
 - error in orientation relative to gravity =>
 - incorrect cancellation of the gravity vector.
- Accelerometer data is integrated twice to obtain the position => gravity vector error leads to quadratic error in position.
- All IMUs drift after some time
 - Use of external reference for correction:
 - compass, GPS, cameras, localization

Ground-Based Active and Passive Beacons

- “Elegant” way to solve the localization problem in mobile robotics
- Beacons are signaling guiding devices with a precisely known position
- Beacon base navigation is used since the humans started to travel
 - Natural beacons (landmarks) like stars, mountains or the sun
 - Artificial beacons like lighthouses
- The recently introduced Global Positioning System (GPS) revolutionized modern navigation technology
 - Already one of the key sensors for outdoor mobile robotics
 - For indoor robots GPS is not applicable,
- Major drawback with the use of beacons in indoor:
 - Beacons require changes in the environment
-> costly.
 - Limit flexibility and adaptability to changing environments.

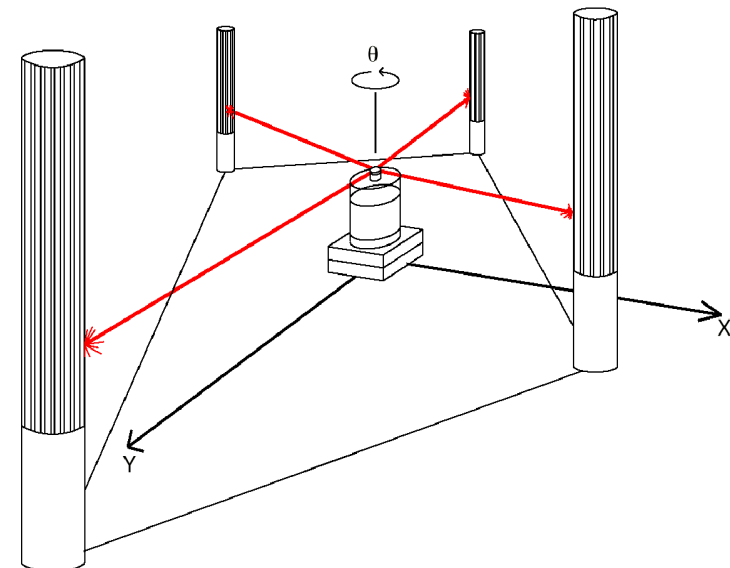

Global Positioning System (GPS) (1)

- Developed for military use
- 1995 it became accessible for commercial applications
- 24 satellites orbiting the earth every 12 hours at a height of 20.190 km.
- 4 satellites are located in each of 6 orbits with 60 degrees orientation between each other. The orbital planes do not rotate with respect to stars. Orbits arranged so that at least 6 satellites are always within line of sight from any point on Earth's surface.
- From 2008: 32 satellites to improve localization accuracy through redundancy
- Location of any GPS receiver is determined through a time of flight measurement (satellites send orbital location (*ephemeris*) plus time; the receiver computes its location through **trilateration** and **time correction**)
- Technical challenges:
 - Time synchronization between the individual satellites and the GPS receiver
 - Real time update of the exact location of the satellites
 - Precise measurement of the time of flight
 - Interferences with other signals

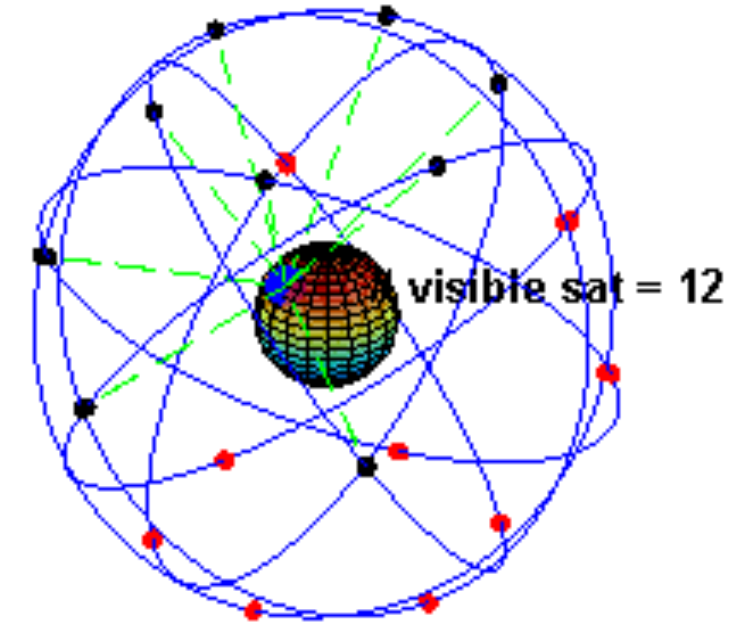

Global Positioning System (GPS) (2)

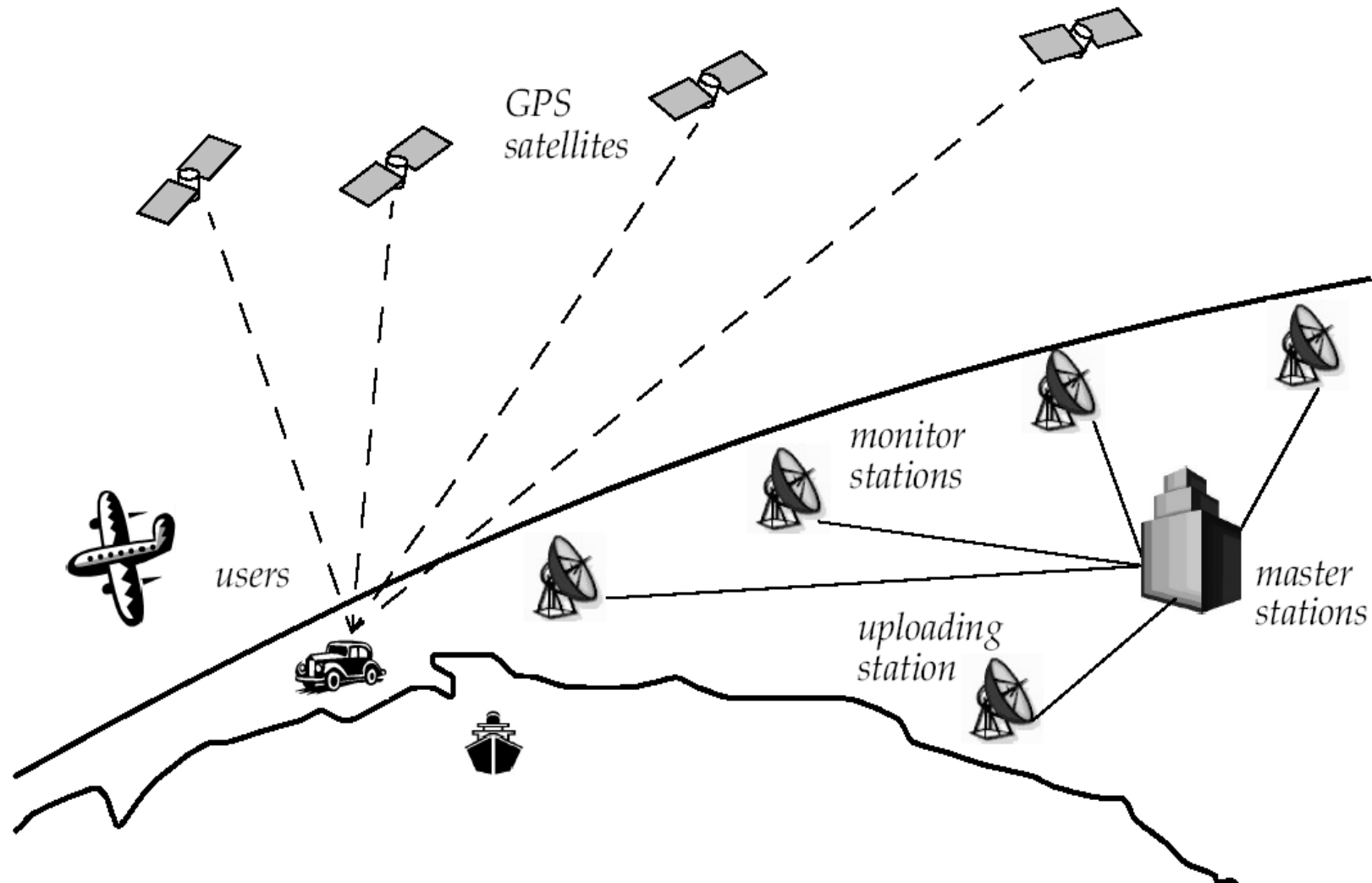

Global Positioning System (GPS) (3)

- Time synchronization:
 - atomic clocks on each satellite
 - monitoring them from different ground stations.
- Ultra-precision time synchronization is extremely important
 - electromagnetic radiation propagates at light speed
- Roughly 0.3 m per nanosecond
 - position accuracy proportional to precision of time measurement
- Real time update of the exact location of the satellites:
 - monitoring the satellites from a number of widely distributed ground stations
 - master station analyses all the measurements and transmits the actual position to each of the satellites
- Exact measurement of the time of flight
 - the receiver correlates a pseudocode with the same code coming from the satellite
 - The delay time for best correlation represents the time of flight.
 - quartz clock on the GPS receivers are not very precise
 - the range measurement with four satellite allows to identify the three values (x, y, z) for the position and the clock correction ΔT
- Recent commercial GPS receiver devices allows position accuracies down to a couple meters.

GPS Error Sources

Satellite clock errors uncorrected by monitor stations may result in one meter errors:

- Ephemeris data errors: 1 meter
- Tropospheric delays: 1 meter.
 - The troposphere is the lower part (ground level to from 8 to 13 km) of the atmosphere that experiences the changes in temperature, pressure, and humidity associated with weather changes. Complex models of tropospheric delay require estimates or measurements of these parameters.
- Unmodeled ionosphere delays: 10 meters.
 - The ionosphere is the layer of the atmosphere from 50 to 500 km that consists of ionized air. The transmitted model can only remove about half of the possible 70 ns of delay leaving a ten meter unmodeled residual.
- Number of satellites under line of sight

GPS Multipath

- Multipath: 0.5 meters
 - Multipath is caused by reflected signals from surfaces near the receiver that can either interfere with or be mistaken for the signal that follows the straight line path from the satellite. Multipath is difficult to detect and sometime hard to avoid.

Satellite coverage

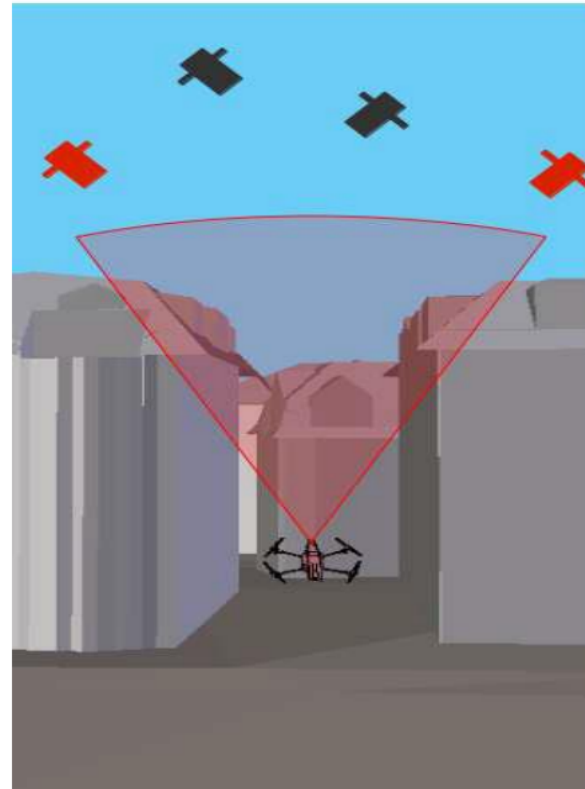

Multipath problem

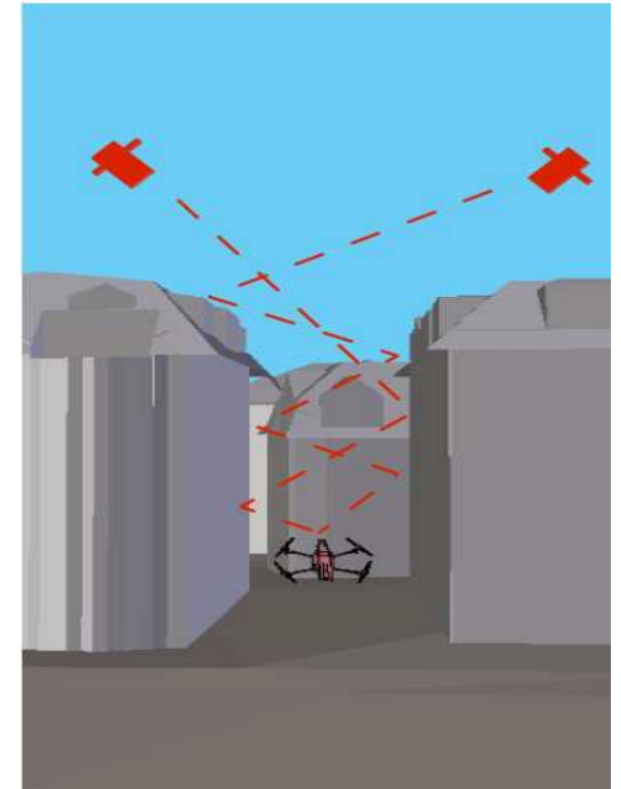

Differential Global Positioning System (dGPS)

- Base station GPS receiver: set up on a precisely known location
- Base station receiver calculates its position based on satellite signals
- Compares this location to the known location
- Difference is applied to the GPS data recorded by the mobile GPS receivers
- Position accuracies in sub-meter to cm range

Differential GPS

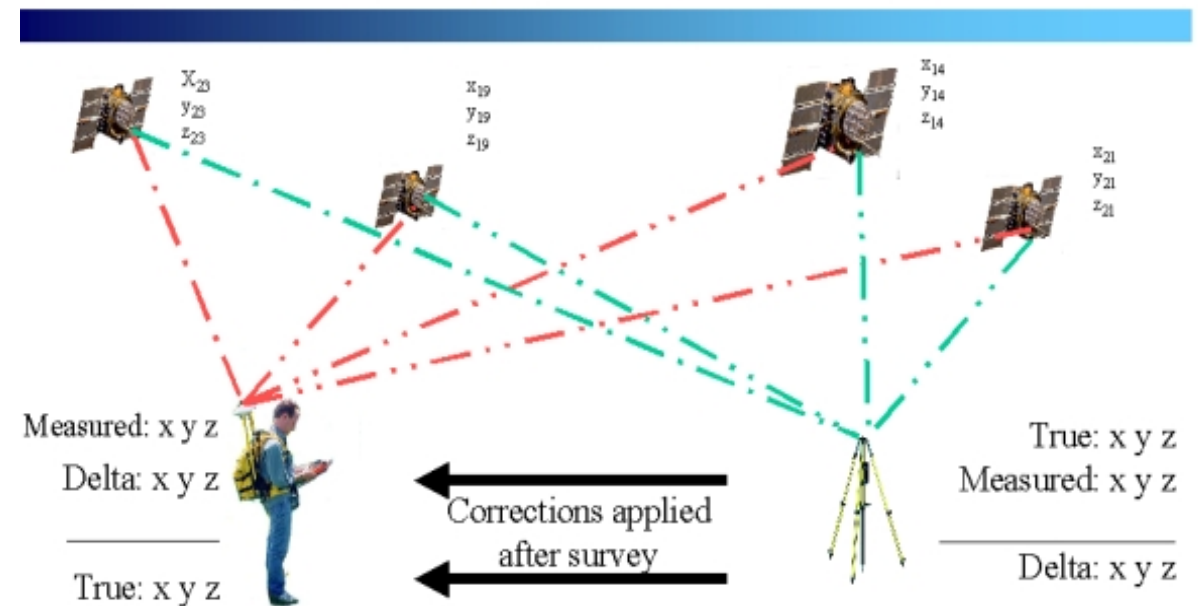

Other Global Positioning Systems

- **GLONASS**
 - Russian GPS – developed since 1976
 - Full global coverage as of 2011 (24 satellites)
- **Galileo**
 - European GPS – initiated 2003
 - Six satellites in orbit
 - Expected completion: 2019
- **IRNSS (Indian Regional Navigation Satellite System)**
 - Initiated 2010
 - 3 out of 7 satellites for Indian Coverage in orbit
 - Completion by 2015
- **BeiDou Navigation Satellite System 北斗卫星导航系统**
 - Chinese GPS – developed since 2003
 - BeiDou Satellite Navigation System (BDS)
 - 2011 full China coverage – 2020 global coverage
 - 37 satellites system

Range sensors

- Sonar ----->



- Laser range finder --->

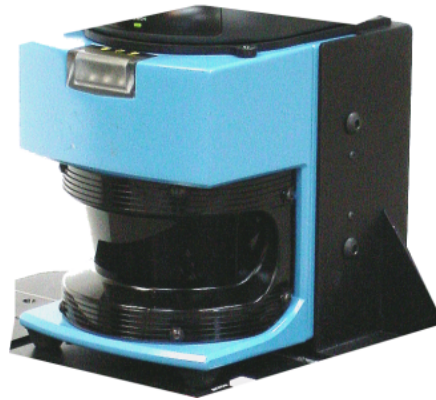

- Time of Flight Camera ----->



- Structured light ----->



Range Sensors (time of flight) (1)

- Large range distance measurement -> called range sensors
 - Range information:
 - key element for localization and environment modeling
 - Ultrasonic sensors as well as laser range sensors make use of propagation speed of sound or electromagnetic waves respectively. The traveled distance of a sound or electromagnetic wave is given by
-
- Where
 - d = distance traveled (usually round-trip)
 - c = speed of wave propagation
 - t = time of flight.

$$d = c \cdot t$$

Range Sensors (time of flight) (2)

- It is important to point out
 - Propagation speed v of sound in air: 0.3 m/ms - 300 m/s
 - Propagation speed v of sound in water: 1.5 m/ms - 1,500 m/s
 - Propagation speed v of electromagnetic signals: 0.3 m/ns,
 - one million times faster.
 - 3 meters
 - is 10 ms for an ultrasonic system
 - only 10 ns for a laser range sensor
 - time of flight with electromagnetic signals is not an easy task
 - laser range sensors expensive and delicate
- The quality of time of flight range sensors mainly depends on:
 - Inaccuracies in the time of flight measure (laser range sensors)
 - Opening angle of transmitted beam (especially ultrasonic range sensors)
 - Interaction with the target (surface, specular reflections)
 - Variation of propagation speed (sound)
 - Speed of mobile robot and target (if not at stand still)

Factsheet: Ultrasonic Range Sensor (1)

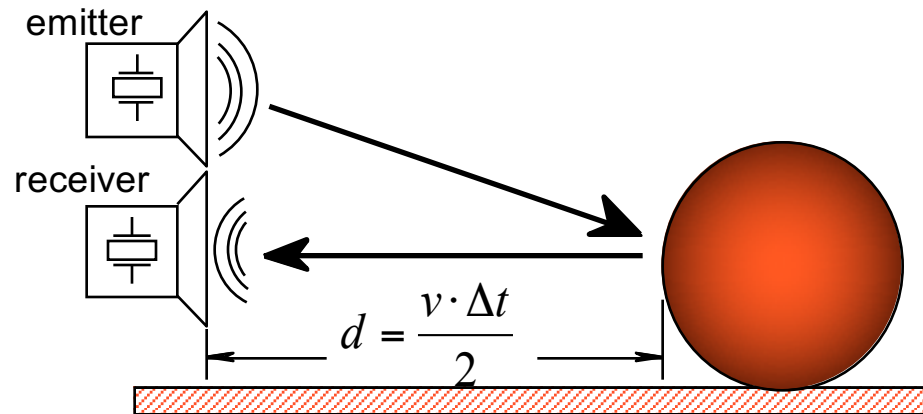

1. Operational Principle

An ultrasonic pulse is generated by a piezo-electric emitter, reflected by an object in its path, and sensed by a piezo-electric receiver. Based on the speed of sound in air and the elapsed time from emission to reception, the distance between the sensor and the object is easily calculated.

2. Main Characteristics

- Precision influenced by angle to object (as illustrated on the next slide)
- Useful in ranges from several cm to several meters
- Typically relatively inexpensive

3. Applications

- Distance measurement (also for transparent surfaces)
- Collision detection

Ultrasonic Sensor (time of flight, sound) (1)

- transmit a packet of (ultrasonic) pressure waves
- distance d of the echoing object can be calculated based on the propagation speed of sound c and the time of flight t .

$$d = \frac{c \cdot t}{2}$$

- The speed of sound c (340 m/s) in air is given by $\sqrt{\gamma \cdot R \cdot T}$

Where

γ : adiabatic index (isentropic expansion factor) - ratio of specific heats of a gas

R : gas constant

T : temperature in degree Kelvin

Ultrasonic Sensor (time of flight, sound) (2)

- typical frequency: 40kHz - 180 kHz
 - Lower frequencies correspond to longer range
- generation of sound wave: piezo transducer
 - transmitter and receiver separated or not separated
- Range between 12 cm up to 5 m
- Resolution of ~ 2 cm
- Accuracy 98% \Rightarrow relative error 2%
- sound beam propagates in a cone (*approx.*)
 - opening angles around 20 to 40 degrees
 - regions of constant depth
 - segments of an arc (sphere for 3D)

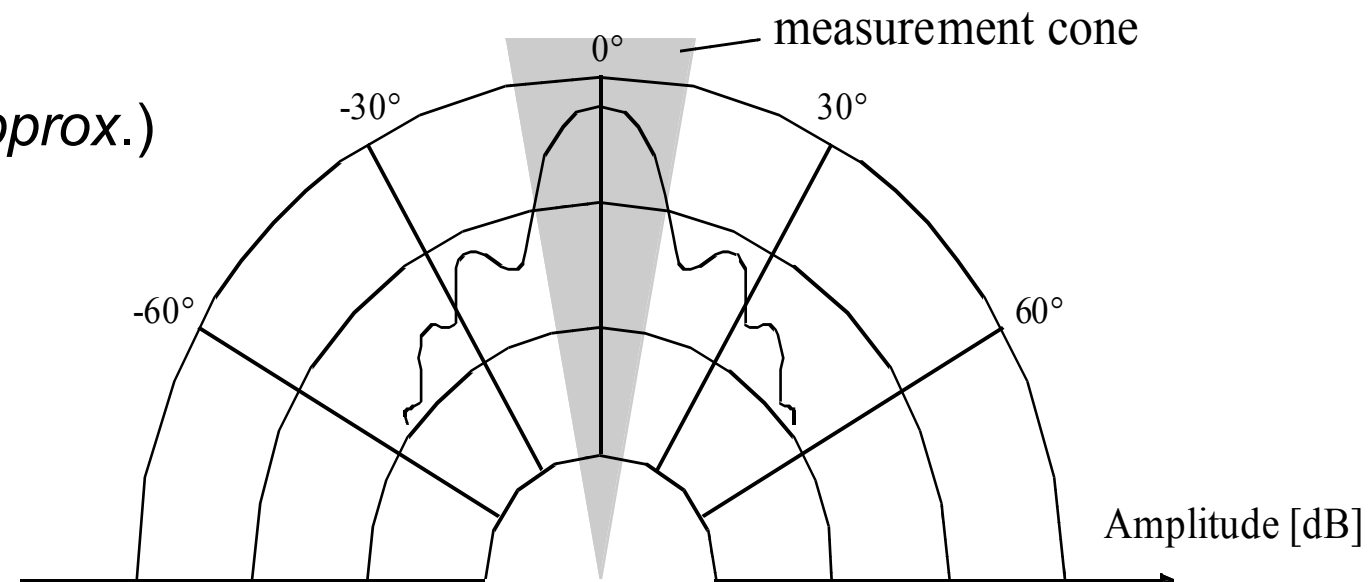

Typical intensity distribution of a ultrasonic sensor

Ultrasonic Sensor (time of flight, sound) (3)

- Other problems for ultrasonic sensors
 - soft surfaces that **absorb** most of the sound energy
 - surfaces that are far from being perpendicular to the direction of the sound -> **specular reflection**

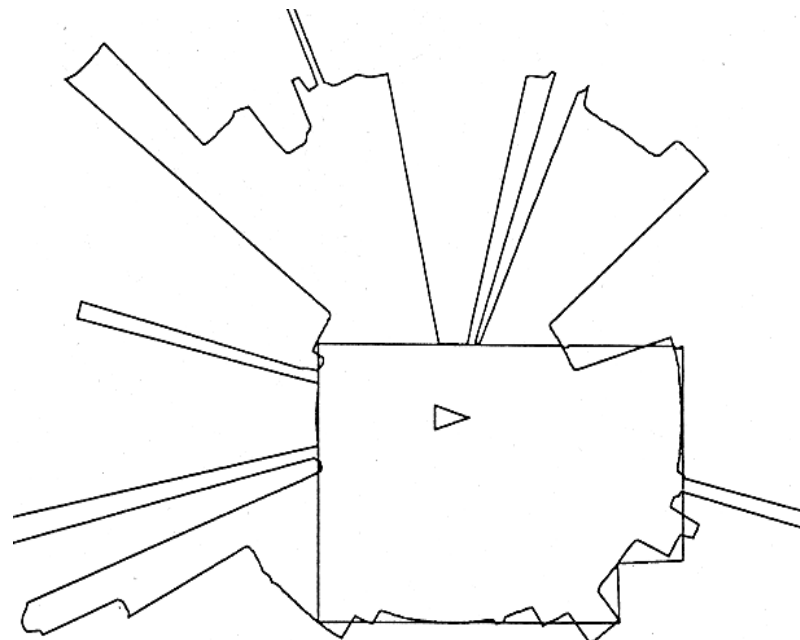

a) 360° scan

0.5 meters

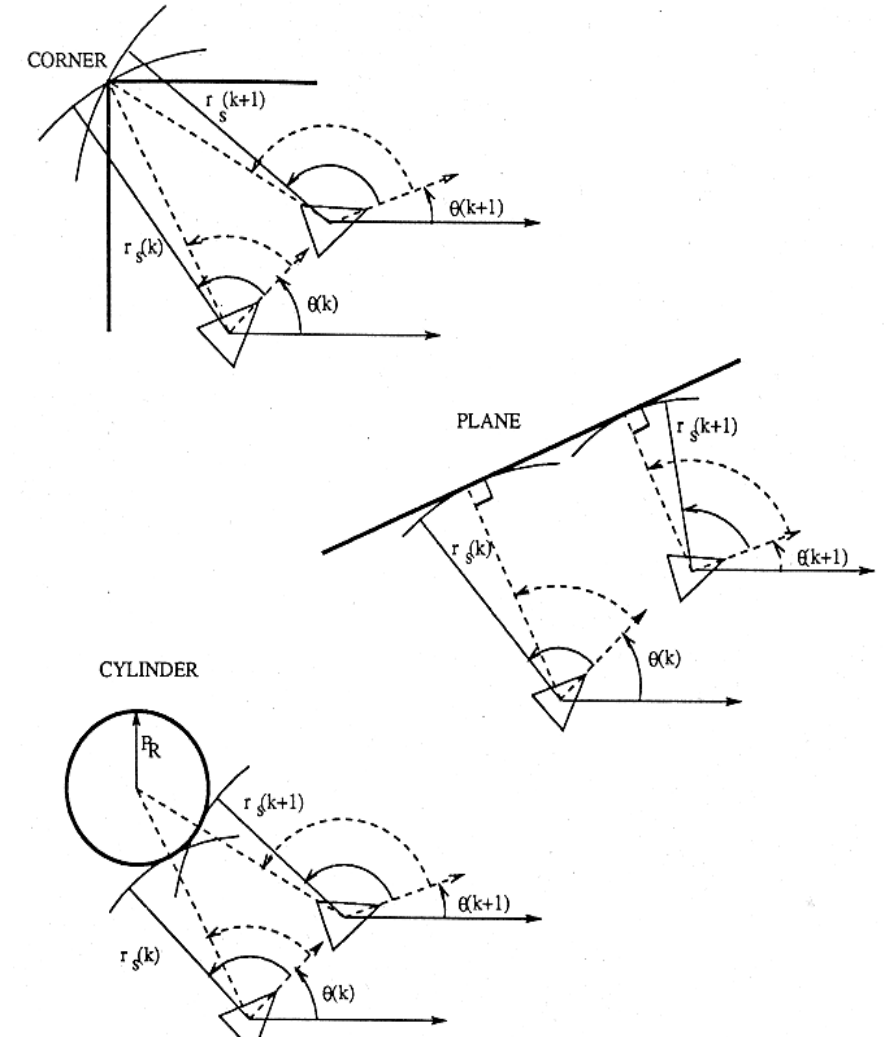

b) results from different geometric primitives

Ultrasonic Sensor (time of flight, sound) (4)

- Bandwidth

- measuring the distance to an object that is 3 m away will take such a sensor 20 ms, limiting its operating speed to 50 Hz. But if the robot has a ring of 20 ultrasonic sensors, each firing sequentially and measuring to minimize interference between the sensors, then the ring's cycle time becomes 0.4 seconds => frequency of each one sensor = 2.5 Hz.
- This update rate can have a measurable impact on the maximum speed possible while still sensing and avoiding obstacles safely.

Laser Range Sensor (time of flight, electromagnetic) (1)

- Is called Laser range finder or Lidar (Light Detection And Ranging)

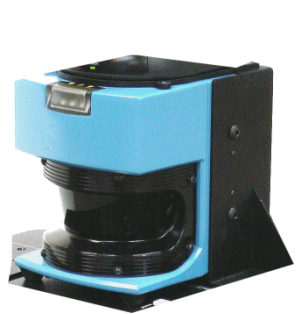

SICK

Germany

High Quality,
Safety Certification
Expensive



Hokuyo

Japan

Small sizes,
Popular for Robotics



Velodyne

USA

3D Sensor (32 beams),
For autonomous cars,
Extremely Expensive

Laser Range Sensor (time of flight, electromagnetic) (1)

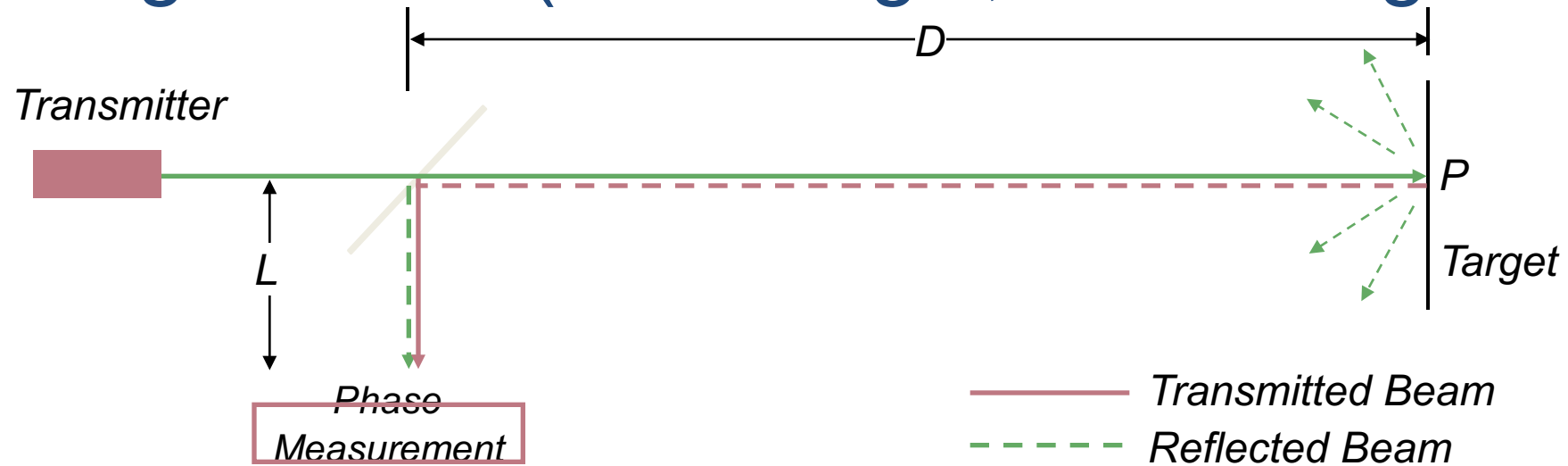

- Transmitted and received beams coaxial
- Transmitter illuminates a target with a collimated laser beam
- Receiver detects the time needed for round-trip
- A mechanical mechanism with a mirror sweeps
 - 2D or 3D measurement

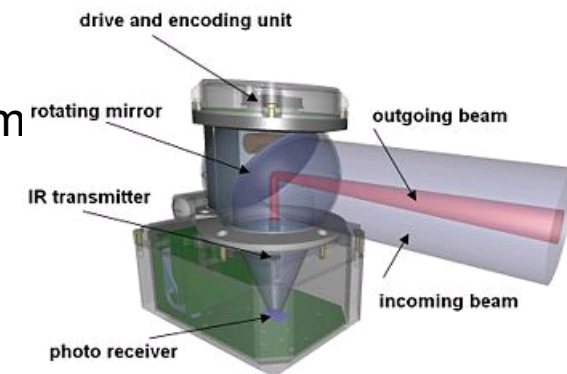

Laser Range Sensor (time of flight, electromagnetic) (2)

Time of flight measurement

- Pulsed laser (today the standard)
 - measurement of elapsed time directly
 - resolving picoseconds
- Phase shift measurement to produce range estimation
 - technically easier than the above method

Laser Range Sensor (time of flight, electromagnetic) (3)

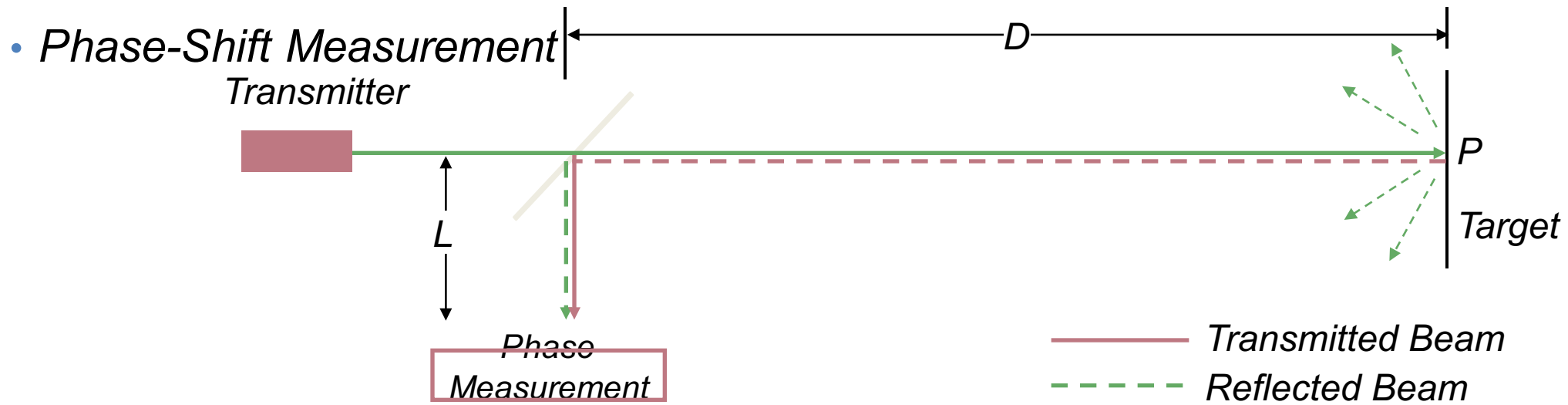

$$D' = L + 2D = L + \frac{\theta}{2\pi} \lambda$$

$$\lambda = \frac{c}{f}$$

Where:

c : is the speed of light; f the modulating frequency; D' the distance covered by the emitted light is.

- for $f = 5$ MHz (as in the A.T&T. sensor), $\lambda = 60$ meters

Laser Range Sensor (time of flight, electromagnetic) (4)

- Distance D , between the beam splitter and the target

$$D = \frac{\lambda}{4\pi} \theta$$

- where
 - θ : phase difference between transmitted and reflected beam
- Theoretically ambiguous range estimates
 - since for example if $\lambda = 60$ meters, a target at a range of 5 meters = target at 35 meters

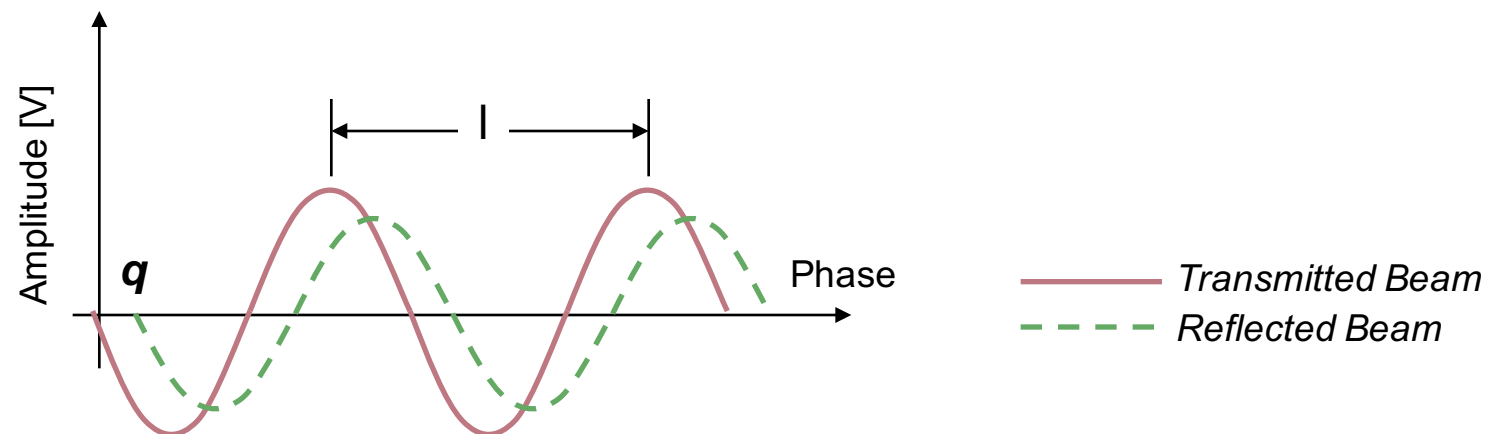

Laser Range Sensor (time of flight, electromagnetic) (5)

- Uncertainty of the range (phase/time estimate) is inversely proportional to the square of the received signal amplitude.
 - Hence dark, distant objects will not produce such good range estimated as closer brighter objects ...

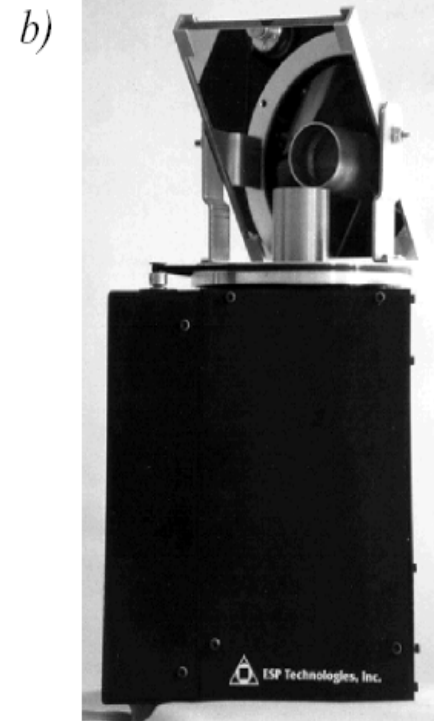
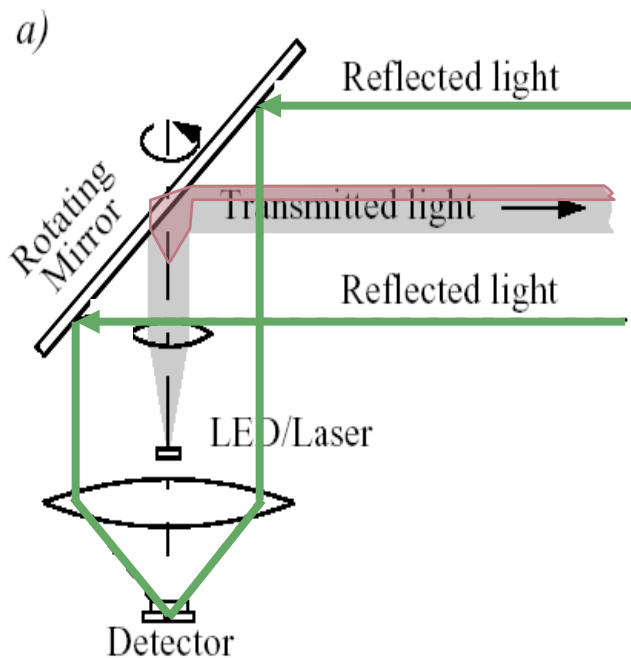

Laser Range Sensor (time of flight, electromagnetic)

- Typical range image of a 2D laser range sensor with a rotating mirror. The length of the lines through the measurement points indicate the uncertainties.

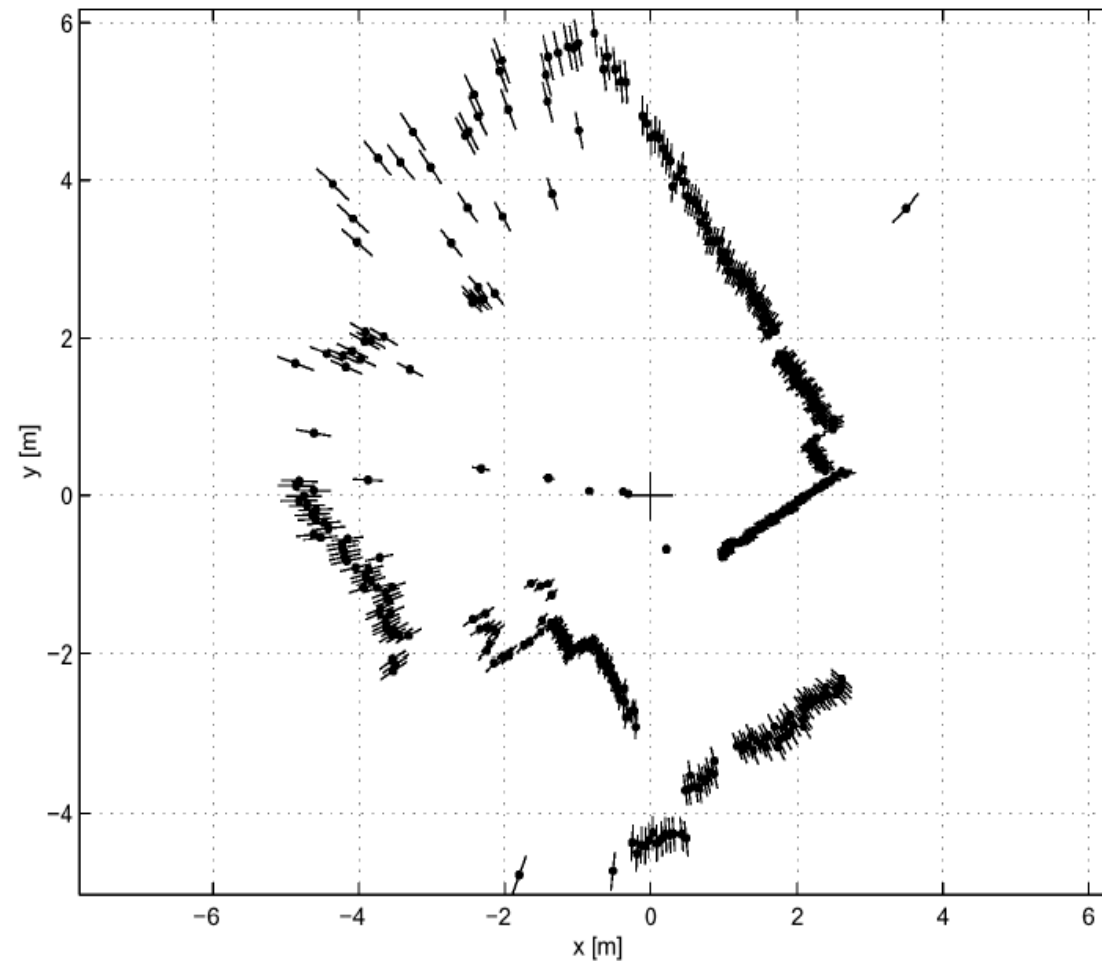

The SICK LMS 200 Laser Scanner

- Angular resolution 0.25 deg
- Depth resolution ranges between 10 and 15 mm and the typical accuracy is 35 mm, over a range from 5 cm up to 20 m or more (up to 80 m)
 - depending on the reflectivity of the object being ranged.
- This device performs seventy five 180-degrees per sec.
- Dimensions: W155 x D155 x H210mm,
- Weight: 1,2 kg
- Cost: about RMB 22,000

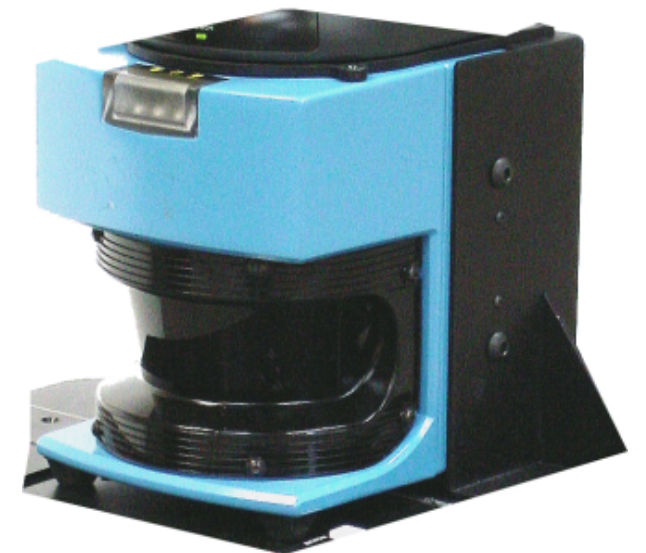

Hokuyo UTM-30LX

- Long Detection range: 30m
- 0.1 to 10m: $\pm 30\text{mm}$, 1
- 0 to 30m: $\pm 50\text{mm}^*1$
- Field of View: 270°
- 40Hz
- Outdoor Environment
- Dimensions: 60 x 60 x 87 mm
- Weight: 370g

- Cost: about 35,000 RMB



URG-04LX-UG01

- Low-power consumption (2.5W)
- Wide-range (5600mm×240°).
- 60 to 1,000mm : ± 30 mm,
- 1,000 to 4,095mm : $\pm 3\%$ of measurement
- 10Hz
- Dimensions: 50 x 50 x 70 mm
- Weight: 160g

- Cost: about 6,500 RMB



Velodyne hdl-32e

- Range: up to 80 – 100 m
- +10.67 to -30.67 degrees field of view (vertical)
- 360° field of view (horizontal)
- 10 Hz frame rate
- Accuracy: <2 cm (one sigma at 25 m)
- Angular resolution (vertical) 1.33°
- 700,000 points per second
- internal MEMS accelerometers and gyros for six-axis motion correction

- Dimensions:
 - Diameter: 85mm,
 - Deight: 144 mm
- Weight: 1kg
- Cost: about 220,000 RMB

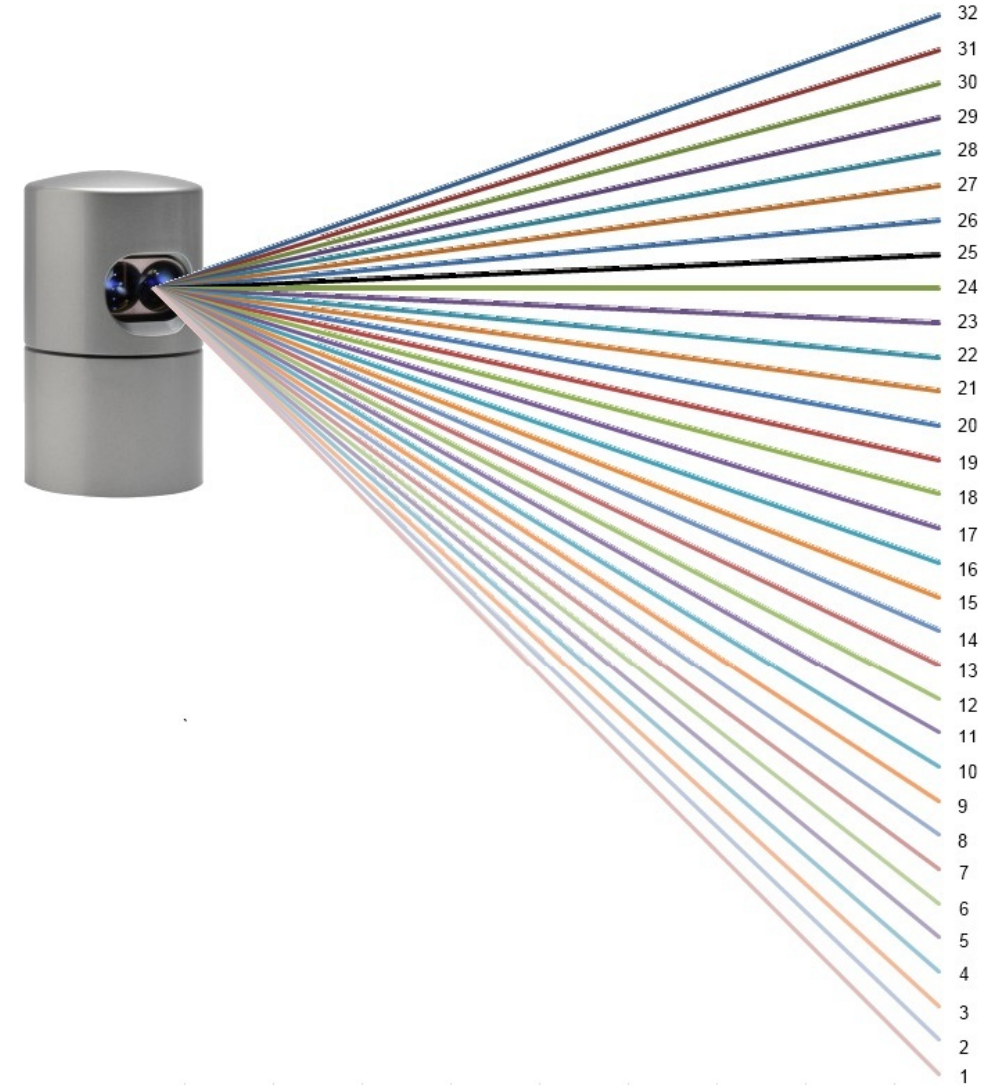

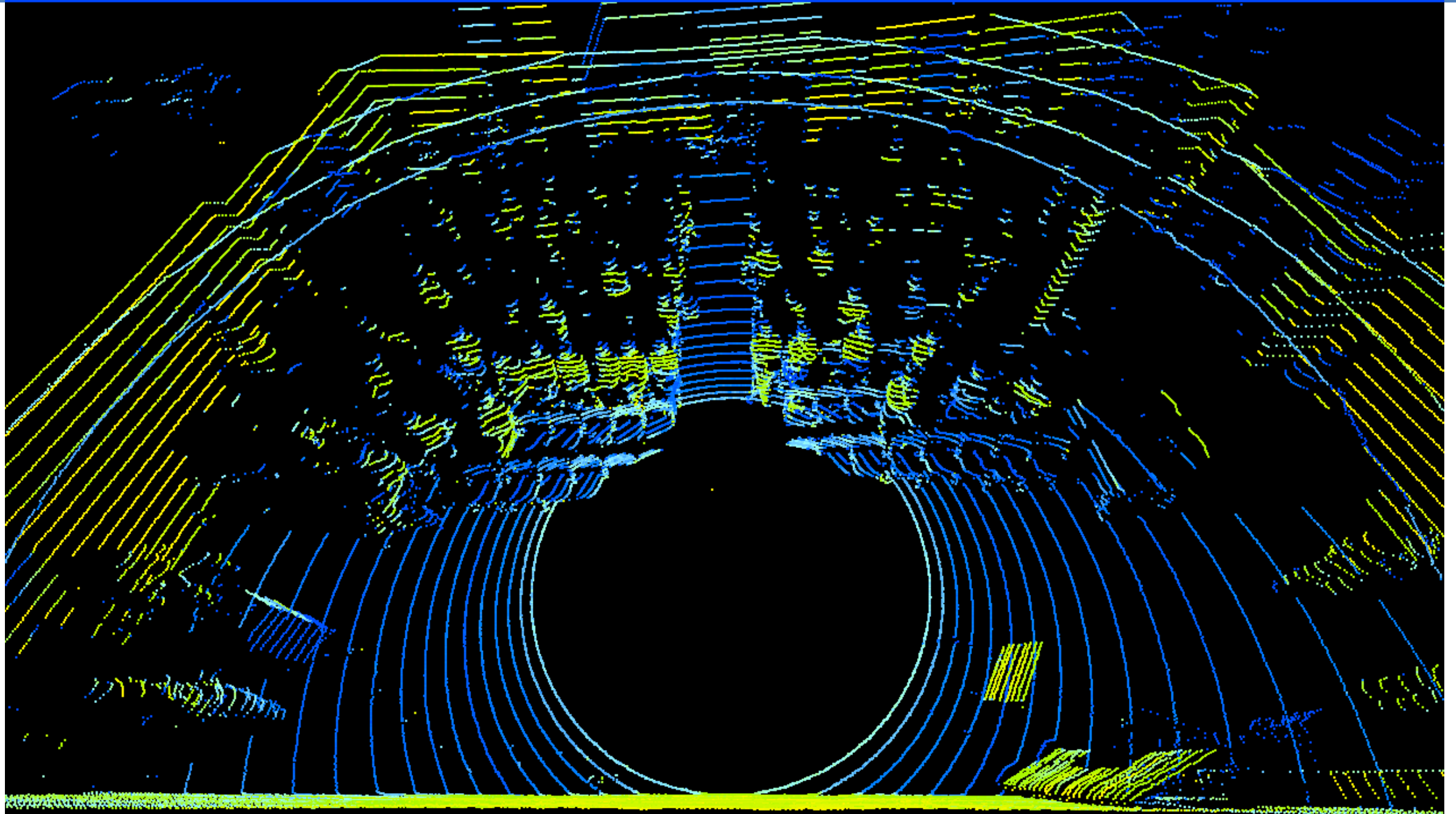

Laser Range Finder: Applications



Stanley: Stanford
(winner of the 2005 Darpa Grand Challenge)



Jack the Gripper
Jacobs University – DLR SpaceBot Cup

3D Laser Range Finder (LRF) (1)

- A 3D laser range finder is a laser scanner that acquires scan data in more than a single plane.
- Custom-made 3D scanners are typically built by nodding or rotating a 2D scanner in a stepwise or continuous manner around an axis parallel to the scanning plane.
- By lowering the rotational speed of the turn-table, the angular resolution in the horizontal direction can be made as small as desired.
- A full spherical field of view can be covered (360° in azimuth and 90° in elevation).
- However, acquisition takes up to some seconds!

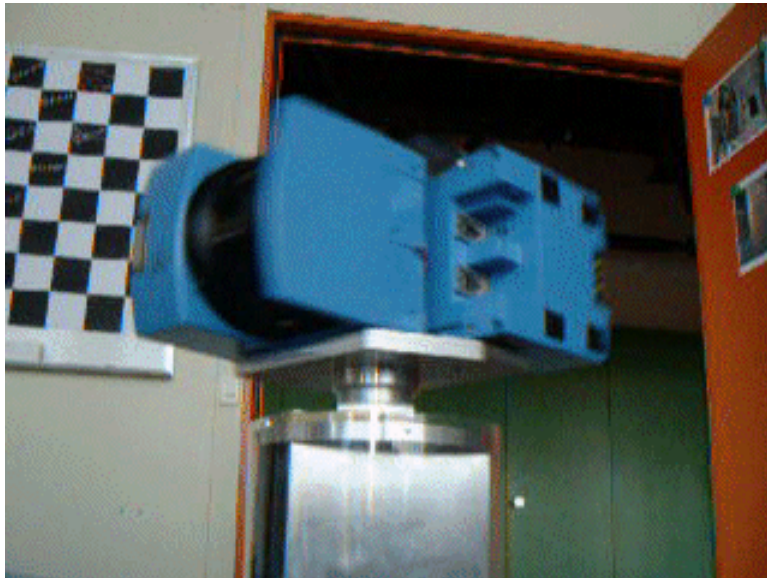

3D Point

- Points below
- Extracted pla

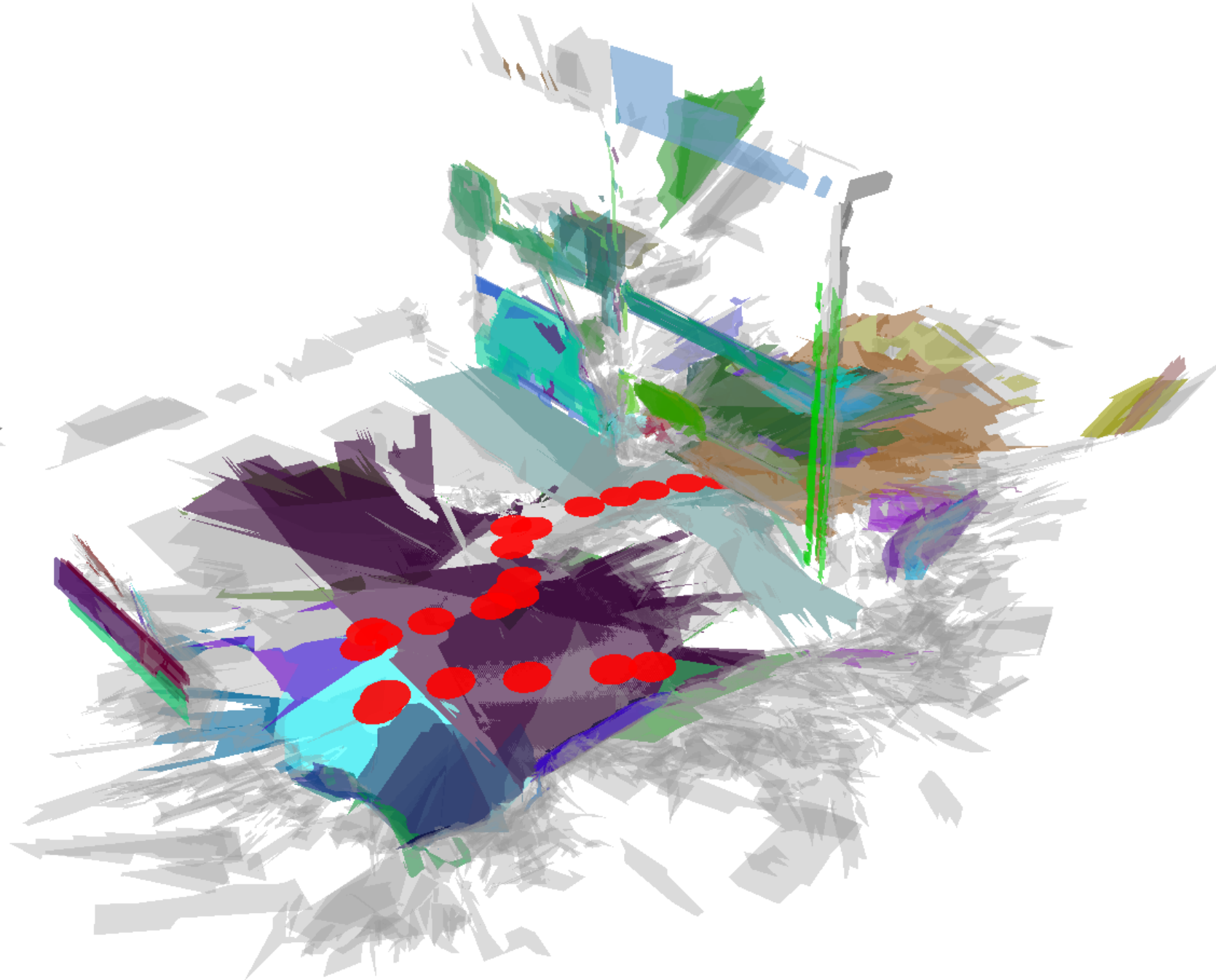
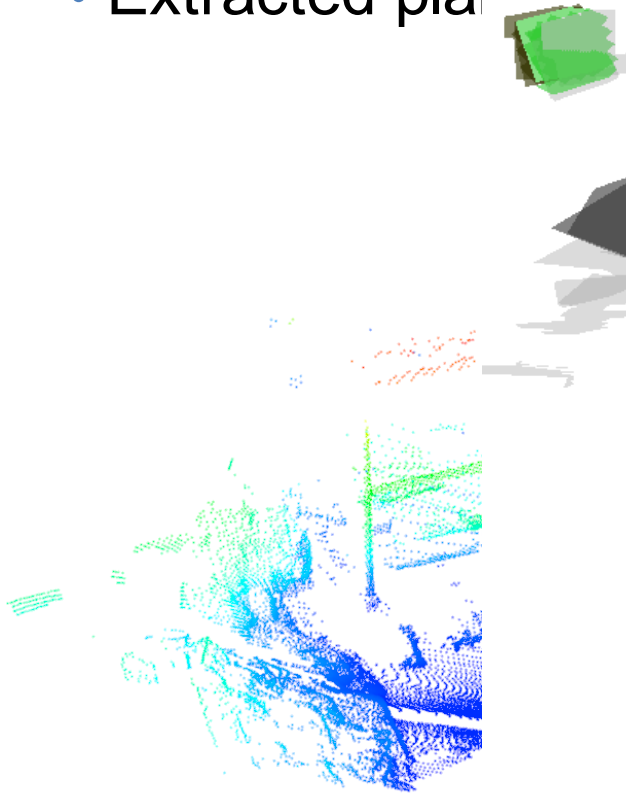

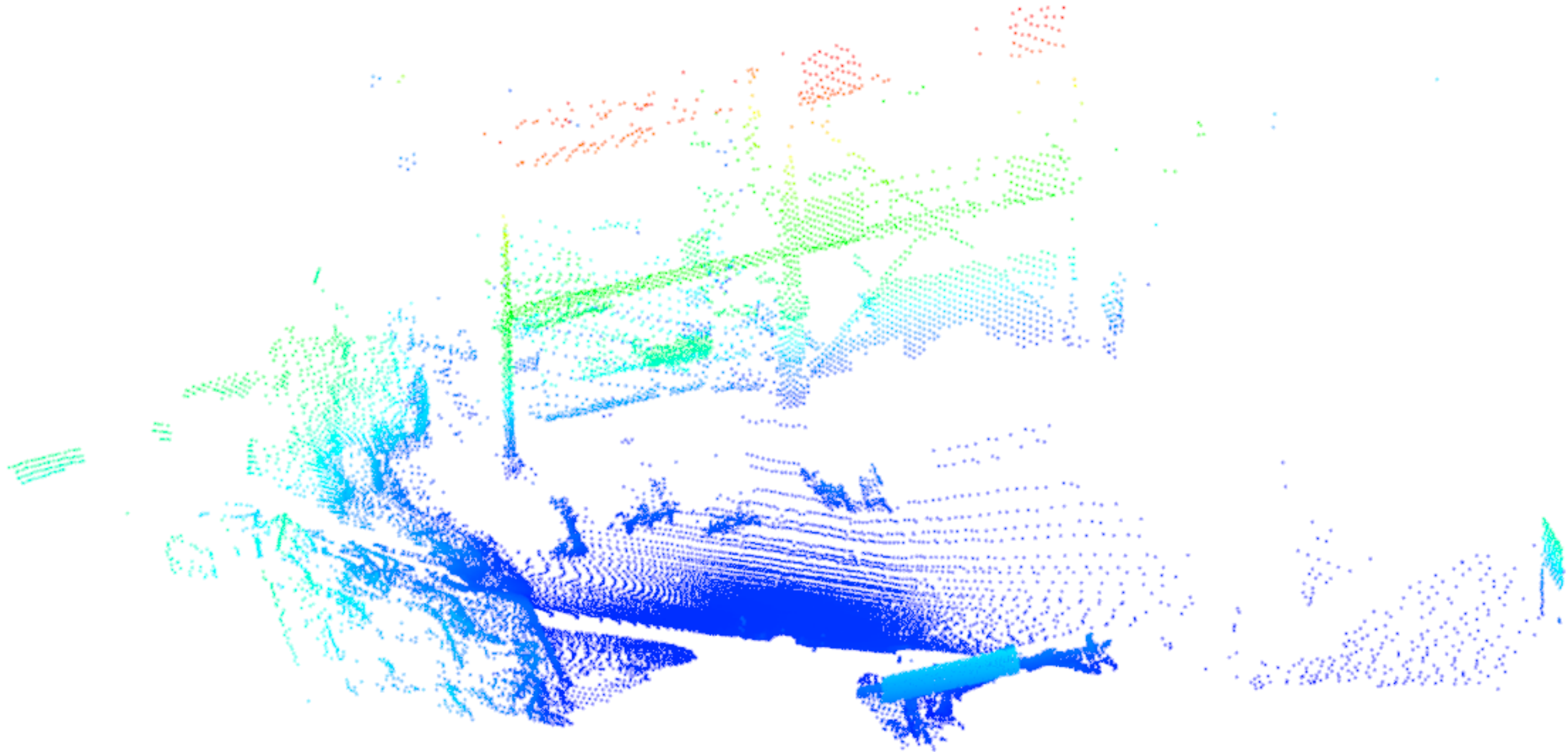

3D Range Sensor (4): Time Of Flight (TOF) camera

- A Time-of-Flight camera (TOF camera, figure) works similarly to a lidar with the advantage that the whole 3D scene is captured at the same time and that there are no moving parts. This device uses a modulated infrared lighting source to determine the distance for each pixel of a Photonic Mixer Device (PMD) sensor.



ZCAM
(from 3DV Systems now bought by Microsoft for Project Natal)

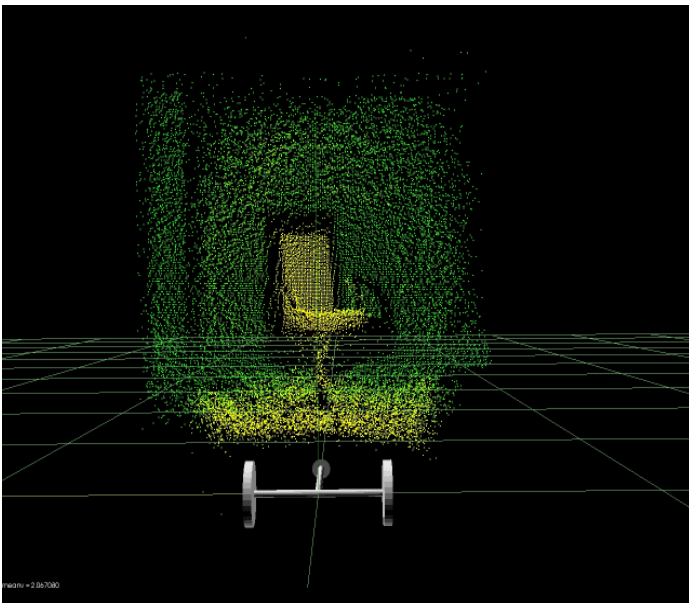

Swiss Ranger 3000
(produced by MESA)

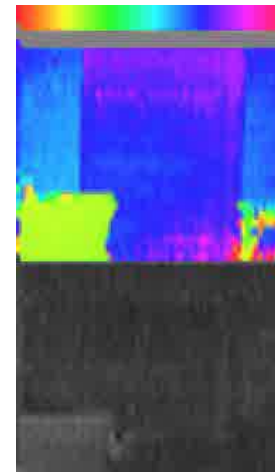

3D Range Sensor (4): Time Of Flight (TOF) camera

- Range Camera
 - 3D information with high data rate (100 Hz)
 - Compact and easy to manage
 - High, non-uniform measurement noise
 - High outlier rate at jump edges
 - However very low resolution (174x144 pixels)
 - ZCAM achieves 320x240 pixels
- Sensitive to ambient infrared light!

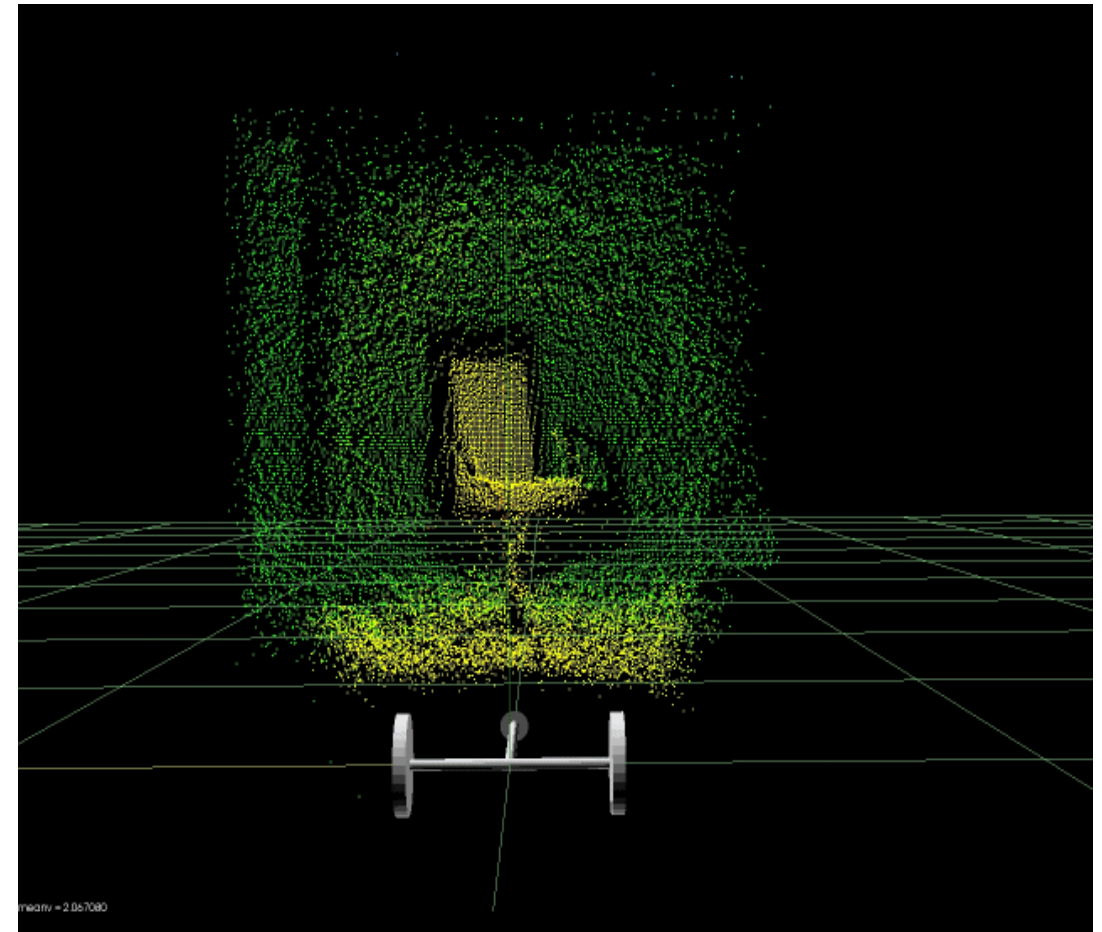

Triangulation Ranging

- Geometrical properties of the image to establish a distance measurement
- e.g. project a well defined light pattern (e.g. point, line) onto the environment.
 - reflected light is then captured by a photo-sensitive line or matrix (camera) sensor device
 - simple triangulation allows to establish a distance.
- e.g. size of an captured object is precisely known
 - triangulation without light projecting

Laser Triangulation (1D)

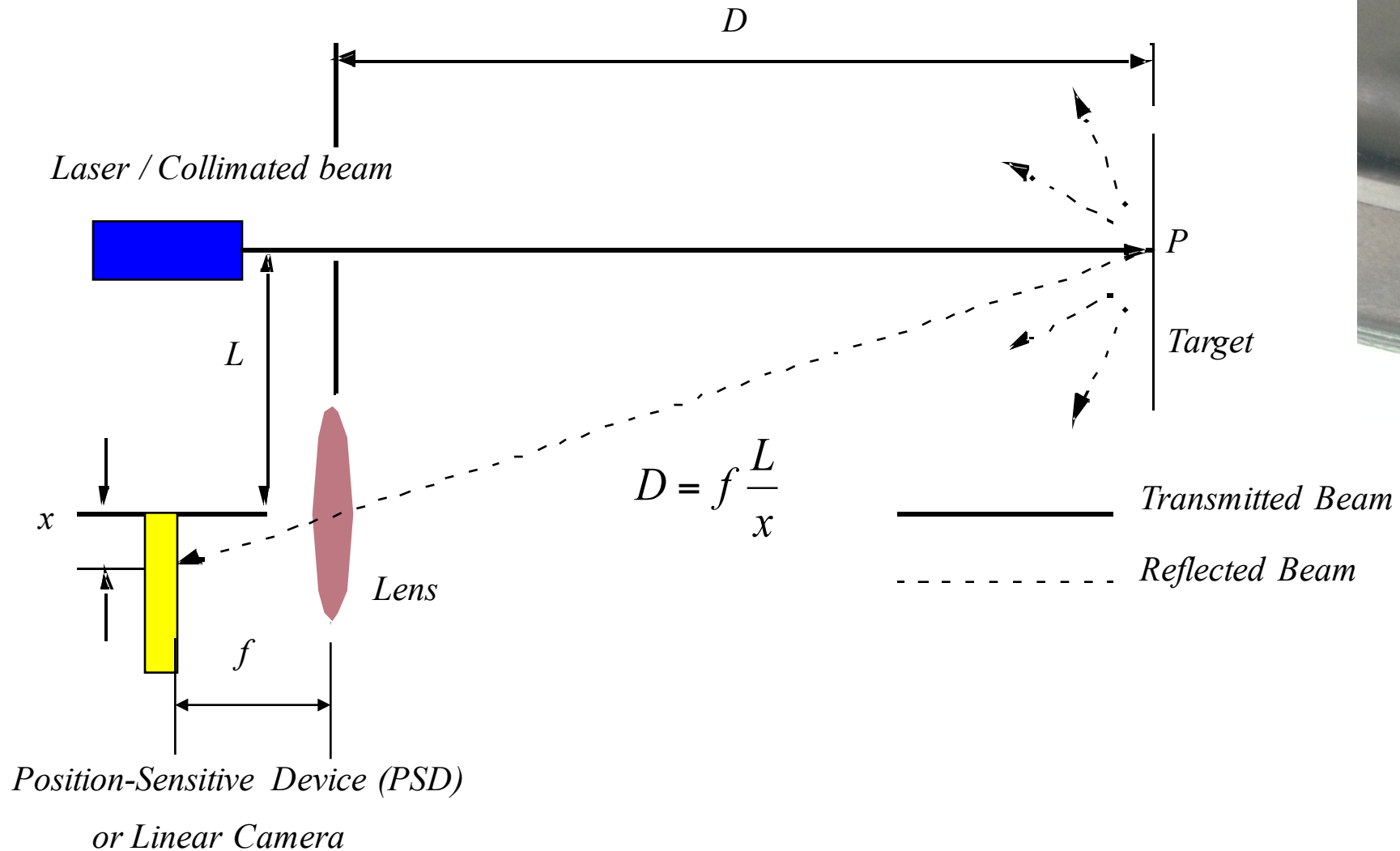

Cliff sensor on Turtle-bot

Structured Light (vision, 2 or 3D): Structured Light

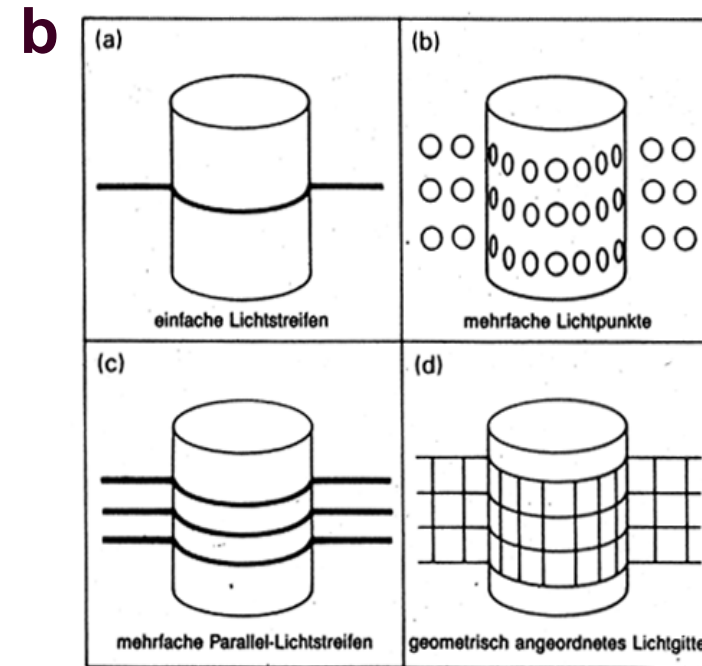
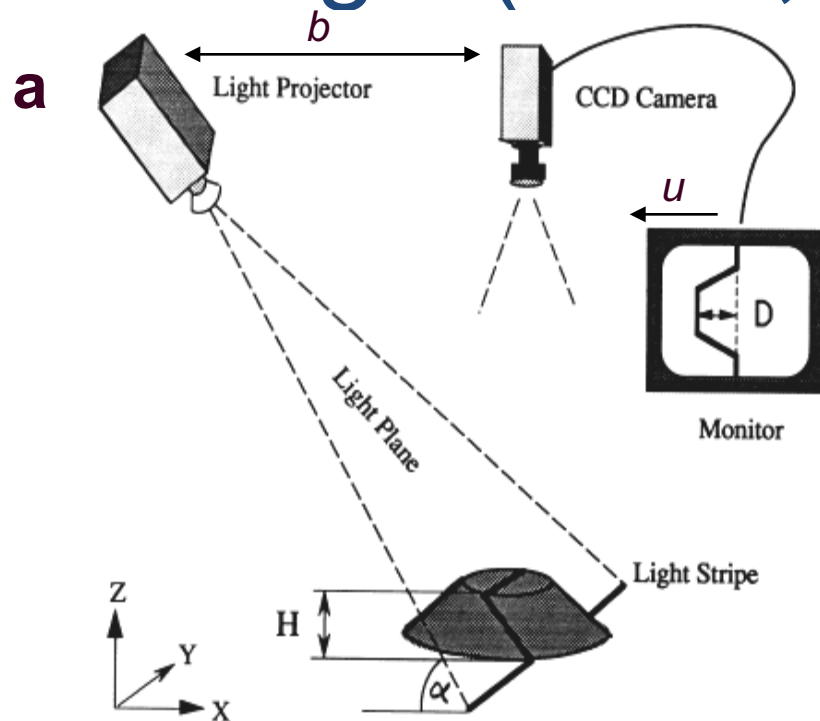

- Eliminate the correspondence problem by projecting structured light on the scene.
- Slits of light or emit collimated light (possibly laser) by means of a rotating mirror.
- Light perceived by camera
- Range to an illuminated point can then be determined from simple geometry.

Structured Light (vision, 2 or 3D)

- Baseline length b :
 - the smaller b is the more compact the sensor can be.
 - the larger b is the better the range resolution is.

Note: for large b , the chance that an illuminated point is not visible to the receiver increases.

- Focal length f :
 - larger focal length f can provide
 - either a larger field of view
 - or an improved range resolution
 - however, large focal length means a larger sensor head

PrimeSense Cameras

- Devices: Microsoft Kinect and Asus Xtion
- Developed by Israeli company PrimeSense in 2010
- Components:
 - IR camera (640 x 480 pixel)
 - IR Laser projector
 - RGB camera (640 x 480 or 1280 x 1024)
 - Field of View (FoV):
 - 57.5 degrees horizontally,
 - 43.5 degrees vertically



IR Pattern



Depth Map



Microsoft Kinect: Depth Computation (1)

• Depth from Stereo

- The Kinect uses an infrared projector and an infrared sensor; it does not use its RGB camera for depth computation
- The technique of analyzing a known pattern is structured light
- The IR projector projects a pseudo-random pattern across the surface of the room.
- The direction of each speckle of the pattern is known (from pre calibration during manufacturing) and is hardcoded into the memory of the Kinect
- By measuring the position of each speckle in the IR image, its depth can be computed



Microsoft Kinect: Depth Computation (2)

- **Astigmatic lens**

- The Kinect uses a special (“astigmatic”) lens with different focal length in x- and y directions
- A projected circle then becomes an ellipse whose orientation depends on depth

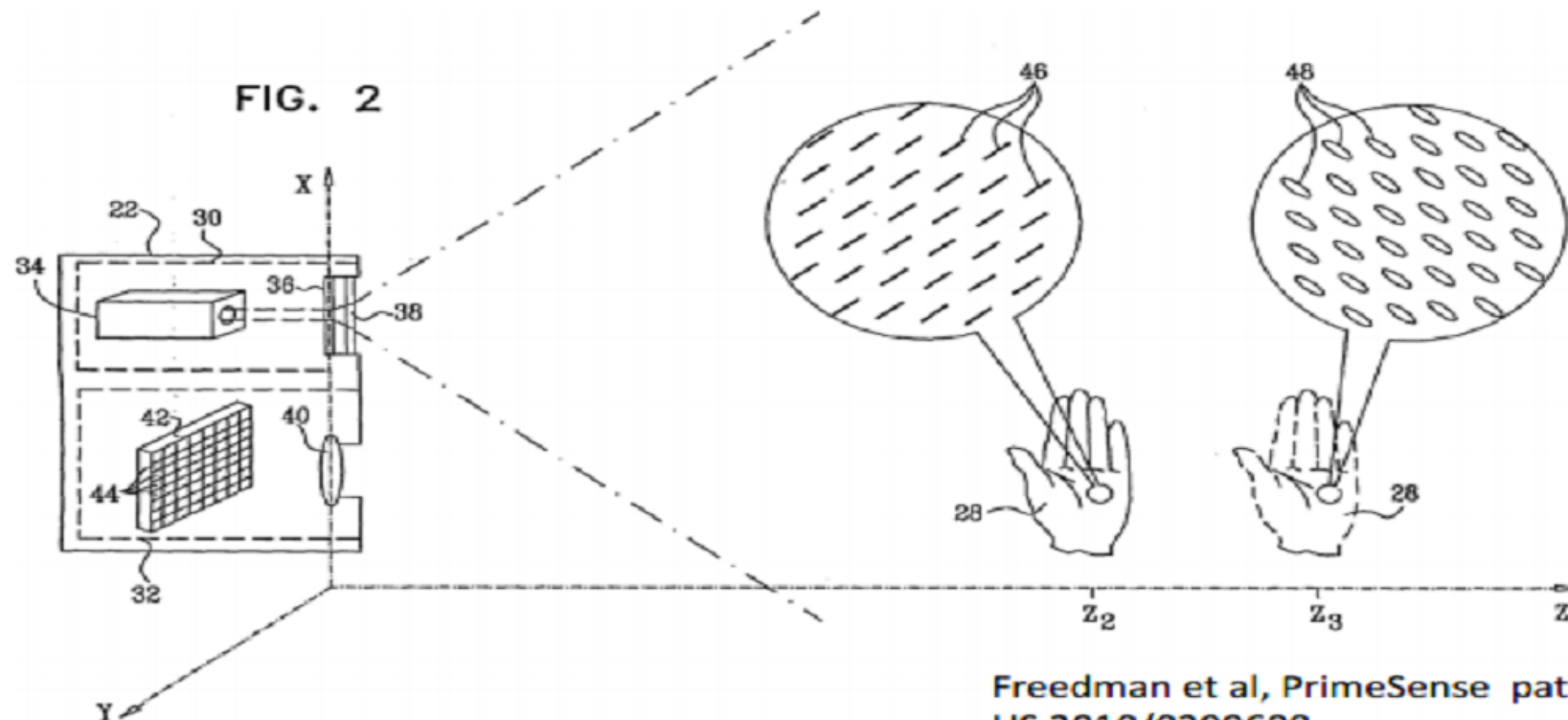

Kinect 2 – time of flight approach

- Resolution 1920x1080 pixels
- Field of view: 70 deg (H), 60 deg (V)
- Claimed accuracy: 1 mm
- Claimed max range: 6 meters

