

# Computer Architecture I Final

Chinese Name: \_\_\_\_\_

Pinyin Name: \_\_\_\_\_

E-Mail ... @shanghaitech.edu.cn: \_\_\_\_\_

Question	Points	Score
1	22	
2	14	
3	20	
4	10	
5	8	
6	10	
7	16	
Total:	100	

- This test contains 9 numbered pages, including the cover page. The back of each page is blank and can be used for scratch-work, but will not be looked at for grading.
- Put your pinyin name on the top of every page.
- Please turn **off** all cell phones, smartwatches, and other mobile devices. Remove all hats and headphones. Put everything in your backpack. Place your backpacks, laptops and jackets under your seat.
- You have 75 minutes to complete this exam. The exam is closed book; no computers, phones, or calculators are allowed. You may use three A4 pages (front and back) of handwritten notes in addition to the provided green sheet.
- The estimated time needed for each of the topics is given in parenthesis. The total estimated time is 75 minutes.
- There may be partial credit for incomplete answers; write as much of the solution as you can. We will deduct points if your solution is far more complicated than necessary. When we provide a blank, please fit your answer within the space provided.
- Answer all questions in English. Answers in Chinese get 50% of the score deducted.

## 1. SDS and Pipeline (20 minutes)

The following sub-questions will use the circuit shown in Figure 1 below.

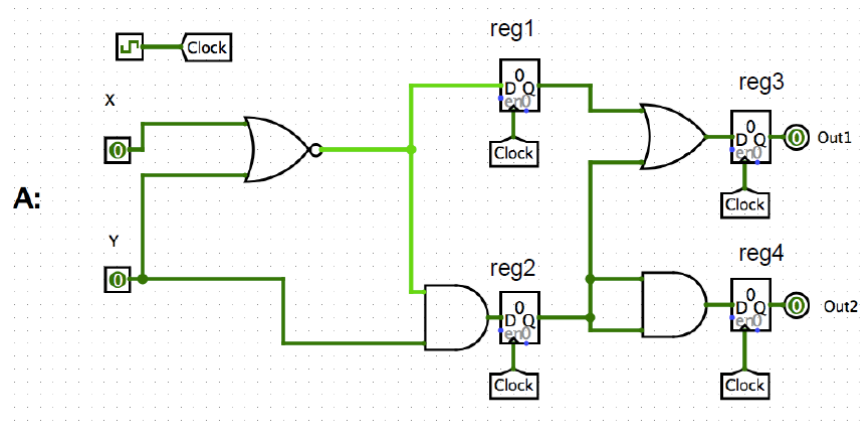

Figure 1

Circuit specs:

- 15ns clk-to-Q time
- Negligible hold time
- 20 ns logical gate propagation delay
- Gates with bubbles on the output have the same delay as "normal" gates
- Assume that X and Y arrive at the positive edge of the clock

6

- (a) Given Circuit A, with a clock period of 100ns, determine the maximum theoretical setup time we can have for this circuit to satisfy register-timing constraints (and function correctly). With this setup time, if signals X and Y are undefined until  $t = 0$ , when would Out1 be stable with the correct computed value?

Max setup time: \_\_\_\_\_

Out1 stable at  $t =$  \_\_\_\_\_

8

- (b) Now, you need to pipeline the circuit to improve the clock period. **Draw a star on any wire in Figure 1 where you would place a pipelining register.** You may place up to 3 registers (but you may not need all 3). Your solution may introduce a cycle delay, but should not change the sequence of outputs after that initial delay (assuming the circuit gets a single uninterrupted stream of incoming X and Y values). Write a short explanation below:



## 2. Control and Datapath (14 minutes)

Modify the following single cycle MIPS datapath diagram to accommodate a new instruction *swai* (store word then auto-increment). The operation performs the regular *sw* operation, then post-increments the *rs* register by 1. Your modification may use simple adders, mux chips, wires, and new control signals. You may replace original labels where necessary. Recall the RTL for *sw* is:  $Mem[R[rs] + SignExt[imm16]] = R[rt]$ ;  $PC = PC + 4$ , & that *sw* (and *swai*) has the following fields:

Opcode	Rs	Rt	Immediate
--------	----	----	-----------

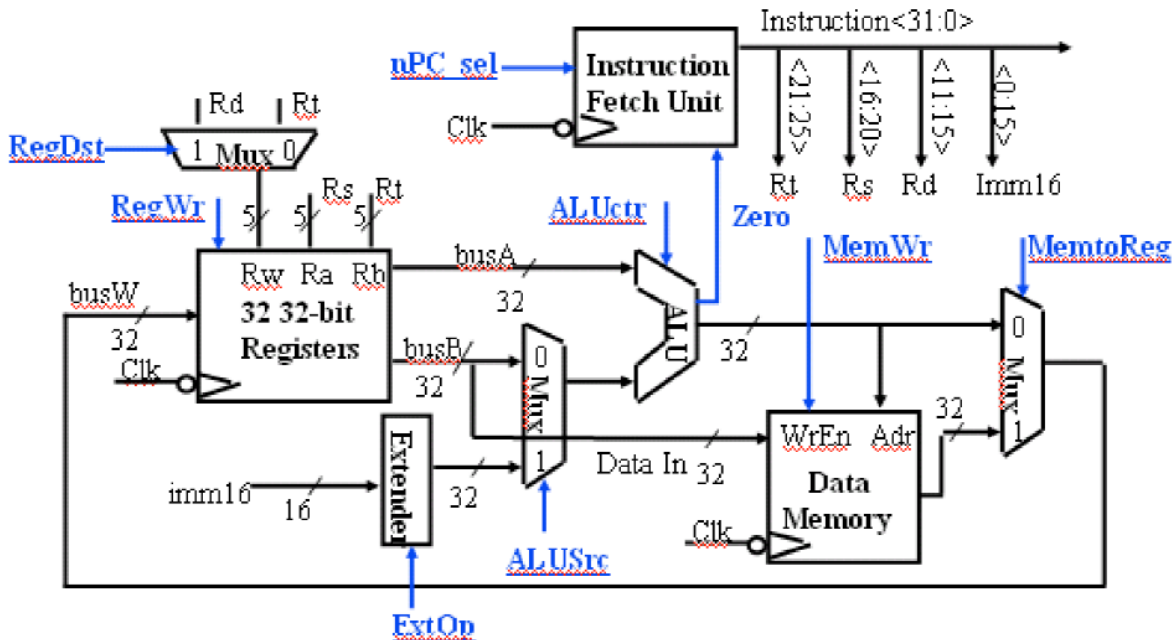

Figure 2: Datapath

10

(a) **Modify the picture above** and list your changes below. You may not need all lines. Write them in "pipeline stage order" (i.e., changes affecting IF first, MEM next, etc.)

(A)

(B)

(C)

(D)

(E)

(F)

4

(b) We also wish to do the same thing with *lw*, namely create *lwai*. Will this work? Please argue your point in one sentence.

## 3. MIPS Mystery (14 minutes)

We present `mystery`, a new helper routine for your C programming.

In parts (a) and (b), you'll show us you know how to use `mystery` form C.

In parts (c) and (d), you'll show us you understand its limitations.

```

mystery:  ori    $v0 $0 0x0
          beq    $a0 $0 done
          la     $t0 mystery
          lw     $t1 0($t0)
          addiu  $t1 $t1 0x1
          sw     $t1 0($t0)
          lw     $v0 0($a0)
done:     jr     $ra

main() {
    char A[4], char4 = '4';
    int pi[] = {3, 4, 1, 5, 1};
    float float4 = 4;
    // part(a)
    // more code, ...
}

```

- 2 (a) If you are at “part (a)” in the C code, show a single call to `mystery` so that it returns 4.

```

printf("Here is mystery returning four...%d\n", mystery(
_____ ) );

```

- 6 (b) Complete the documentation of `mystery` for a fellow programmer. Use good abstraction—don't tell the user how it does what it does, just tell them what it does and how it's to be used.

“When called with a *non-NULL* argument, the subroutine `mystery`...

\_\_\_\_\_”  
 “When called with *NULL* argument, the subroutine `mystery`...

\_\_\_\_\_”  
 “Overall, `mystery` is a subroutine used to ...

- 2 (c) We'd like to know if there is a limit to the # of times `mystery` can be called with a *NULL* argument (so that it still does what you described in part b). If there is, state what the limit is and what happens if it's called one more time. If there isn't a limit, write N/A (not applicable) in both blanks.

“With a *NULL* argument, `mystery` may be called at most \_\_\_\_\_ times, Calling it once more...

\_\_\_\_\_”

- 2 (d) We'd like to know if there is a limit to the # of times `mystery` can be called with a *non-NULL* argument (so that it still does what you described in part b). If there is, state what the limit is and what happens if it's called one more time. If there isn't a limit, write N/A (not applicable) in both blanks.  
 "With a non-NULL argument, `mystery` may be called at most \_\_\_\_\_ times,  
 Calling it once more..."
- 

- 4 (e) Translate the following assembly into machine code.

Instruction	Code
<code>xor \$s0,\$s0,\$s0</code>	

- 4 (f) What is the difference between 'jr', 'jal' and 'j' ?

#### 4. C Programming (10 minutes)

- 4 (a) **Write C Code in One Line.** Complete the following C function according to comments. You may assume that the architecture on which this code is run uses two's complement to represent signed integers. Zero points if you use `if/else` or `?:`. Suggestion: *Use parentheses to explicitly denote the order of operations.*

```

/*
 * Returns an unsigned integer whose first IDX low order bits are
 * the same as that in LO , and whose remaining high order bits
 * are the same as that of HI. Assume 0 <= IDX < sizeof ( int ).
 */
unsigned splice ( unsigned lo , unsigned hi , int idx ) {

    return _____;
}

```

6

(b) **Thread Level Parallelism.** Consider each of the following code segments and determine which of the following statements is true about the correctness/performance of the given code, and *a brief explanation of one or two sentences is a must*. Assume the default number of threads is greater than 1 and no thread will complete before another thread starts executing.

1. Sometimes incorrect
2. Always incorrect
3. Slower than serial
4. Faster than serial

(a) Set all elements in arr to 0.

```
int i;
#pragma omp parallel for
for (i = 0; i < len; i++) {
    arr[i] = 0;
}
```

(b) Set element i of arr to i.

```
#pragma omp parallel
for (int i = 0; i < len; i++) {
    arr[i] = i;
}
```

(c) Set arr to be an array of Fibonacci numbers.

```
arr[0] = 0;
arr[1] = 1;
#pragma omp parallel for
for (int i = 2; i < len; i++) {
    arr[i] = arr[i - 1] + arr[i - 2];
}
```

## 5. Cache (5 minutes)

This C code runs on a 32-bit MIPS machine with 4 GiB of memory and a single L1 cache. Vectors A and B live in different places of memory, are of equal size (n is a power of 2 and a [natural number] multiple of the cache size), block aligned. The size of the cache is C, a power of 2 (and always bigger than the block size, obviously).

```
// sizeof(uint8_t) = 1 byte (12Ish)
swapLeft (uint8_t *A, uint8_t *B, int n) {
    uint8_t tmp; // assume the compiler will use a register for tmp
    for (int i = 0; i < n; ++i)
    {
        tmp = A[i];
        A[i] = B[i];
        B[i] = tmp;
    }
}
```

- 4 (a) If the cache is direct mapped and the best hit:miss ratio is "H:1", what is the block size in bytes?

(a) \_\_\_\_\_

- 4 (b) Assuming a block size of 64 bytes, a cache size of 64KiB and a value for n of 65,536 and that we have just finished filling array B with values and no other processes are being executed. In the optimal case, how many cache misses must we have (i.e.: what is the lowest number of cache misses we can have)?

(b) \_\_\_\_\_

## 6. Virtual Memory (8 minutes)

For the following question, assume that the machine in question has the following parameters:

- 64-bit virtual addresses
- 48 bit physical addresses
- 4KiB pages
- Fully associative TLB with 128 entries and LRU replacement
- Unlimited swap space

- 2 (a) How much physical memory can the machine support at most (in KiB, MiB, GiB or TiB)?

(a) \_\_\_\_\_

- 2 (b) What is the maximum number of pages that a process can use (use of power of two is ok)?

(b) \_\_\_\_\_



- 2 (c) How many bytes of main memory can be at maximum covered by the TLB (in KiB, MiB, GiB or TiB)?

(c) \_\_\_\_\_

- 4 (d) Given the program below, and assuming that the text and data segment are continuous and have a size of less than 2KiB, how much memory will the execution of this program need? Why?

```
#include <list>
int main() {
    std::list<int> li;
    li.push_back(3);
    return li.size();
}
```

(d) \_\_\_\_\_

7. T/F Questions (Circle one. If the circling is unclear, you will receive no credit.) (4 minutes)

- 2 (a) Exceptions in early pipeline stages override exceptions in later stages for a given instruction. (True / False)
- 2 (b) Exceptions are handled in the pipeline stage where they occur. (True / False)
- 2 (c) CPUs need separate instructions to access I/O devices. (True / False)
- 2 (d) Segmentation (base + bound) has fragmentation problems. (True / False)
- 2 (e) RAID: Availability will be increased by increasing MTTF (True / False)
- 2 (f) RAID: Availability will be increased by decreasing MTTR (True / False)
- 2 (g) RAID: Availability will be increased by Redundant data copies (True / False)
- 2 (h) RAID: Availability will be increased by using RAID 0 instead of RAID 1 (True / False)